

“LEADER IN ANIMAL CARE PRODUCTS FOR OVER 60 YEARS”



SSCI

SUBURBAN SURGICAL Co., INC.

275 Twelfth Street, Wheeling, IL 60090

All intellectual material, including the text, graphics and other components of this catalog are Copyrighted by SSCI. Any use or duplication of these intellectual materials, without written consent by SSCI, is strictly forbidden.

Catalog No. 702488-0308

For Product Information Call TOLL-FREE 1-800-323-7366 • (847) 537-9320 • Fax (847) 537-9061
Hours: 8:30am - 5:00pm CST Monday - Friday
Visit our website at: www.suburbansurgical.com

STAINLESS STEEL ANIMAL PEN SYSTEMS

**UNIQUE MODULAR, OFFSET-MOUNTED COMPONENTS
CREATE A MORE SANITARY PEN SYSTEM**

Systems with Stainless Steel Partitions



SFF

Stainless Steel Partition, Facility-Floor Pen System



SRF

Stainless Steel Partition, Raised-Floor Pen System

An animal pen

system is an important investment in your business. Selecting the right pen system can increase your revenues, build equity in your business and attract customers by offering a good first impression of the quality of your care. The right pen system operates smoothly and looks great for years to come with minimal maintenance and no sour kennel smell.

When you invest in a Total Animal Pen System from Suburban Surgical, you'll get all this and more. Precision crafted of heavy-duty stainless steel components, our Total Animal Pen Systems are designed to give you a lifetime of unparalleled performance.

Modular components start with 18-gauge-1.25-in. (3.17cm) square Type 304 stainless steel tubular frames. Mitered corners and fully heli-arc welded joints provide strength and durability while ensuring a positive seal against fluids and debris.

Stainless steel grills with uniform, non-glare finish have .2375-in. (.603cm) diameter vertical spokes spaced 1.5-in. (3.81cm) apart and welded at all contact points to the .312-in. (.792cm) diameter crossmembers spaced a maximum of 10-in. (25.40cm) apart. The crossmembers and spokes are fully heli-arc circumference welded to the tubular frame at all contact points to keep fluids and debris out of the frame, and eliminate any shifting, racking, or rattling. This unitized design keeps animals safer and healthier while in your care.

Four types of lower panels give you options you won't get with other pen systems. Choose our most sanitary single wall, sound-deadening double wall stainless steel lower panels, or laminated or fiberglass reinforced lower panels in a color to coordinate with your décor.

Our Total Pen System is uniquely designed with offset-mounted panels to eliminate tight crevices where dirt and debris can get trapped.

Systems with Masonry Partitions

Stainless steel mounting hardware features 11-gauge brackets, machined screws, and weldnuts permanently welded to the inside of the tubular frame. This exclusive design guarantees a tight, strip-free connection with superior holding power, and allows you to disassemble, rearrange and reassemble your Pen System at any time and still have a tight, sure connection.

With completely modular components, we can design the perfect Total Animal Pen System to meet your needs. And if the need arises, expanding or relocating your Pen System is no problem. Simply add or subtract components to fit your new space.

Whether you need a completely free-standing system or utilize your facility's back or side walls, or even desire a system with masonry partitions, we will work with you to create the right system for you.

We can work with your architect's drawings, or a dimensional drawing with doors and windows indicated. Before ordering, please be sure to see "How to Measure" information at the end of this Section. We want your installation to maximize your available space, fit right, set-up smoothly and provide years of trouble-free service to add to your bottom line.

Let us help you design the most cost effective Pen System for your facility. Please call your SSCI or local authorized representative today and put us to work for you.



MFF

Masonry Partition, Facility-Floor Pen System



MRF

Masonry Partition, Raised-Floor Pen System

Choose from 4 Total Pen System styles:

SFF = A Facility-floor Pen System with Stainless Steel Partitions.

SRF = A Raised-Floor Pen System with Stainless Steel Partitions.

MFF = A Facility-floor Pen System with Masonry Partitions.

MRF = A Raised-floor Pen System with Masonry Partitions

SFF
SRF
MFF
MRF

Look for this symbol on the following pages to help you choose the right components for the Pen System you desire.

Total Animal Pen Systems

SFF

STAINLESS STEEL FACILITY-FLOOR SYSTEMS

This pen configuration uses the floor of your facility as the floor of the pen. The End/Partition Panels have individual leveling feet to accommodate irregularities in your floors. Add our optional Floor Seal Kits to effectively seal sides of individual pens and keep fluids and debris contained, preventing cross-contamination.

This system uses three components to create a totally free-standing pen system: Swinging Gates, End/Partition Panels and Back Panels. If your pen system uses your facility's walls for the back or ends, Back Panels and one or both End Panels can be eliminated.

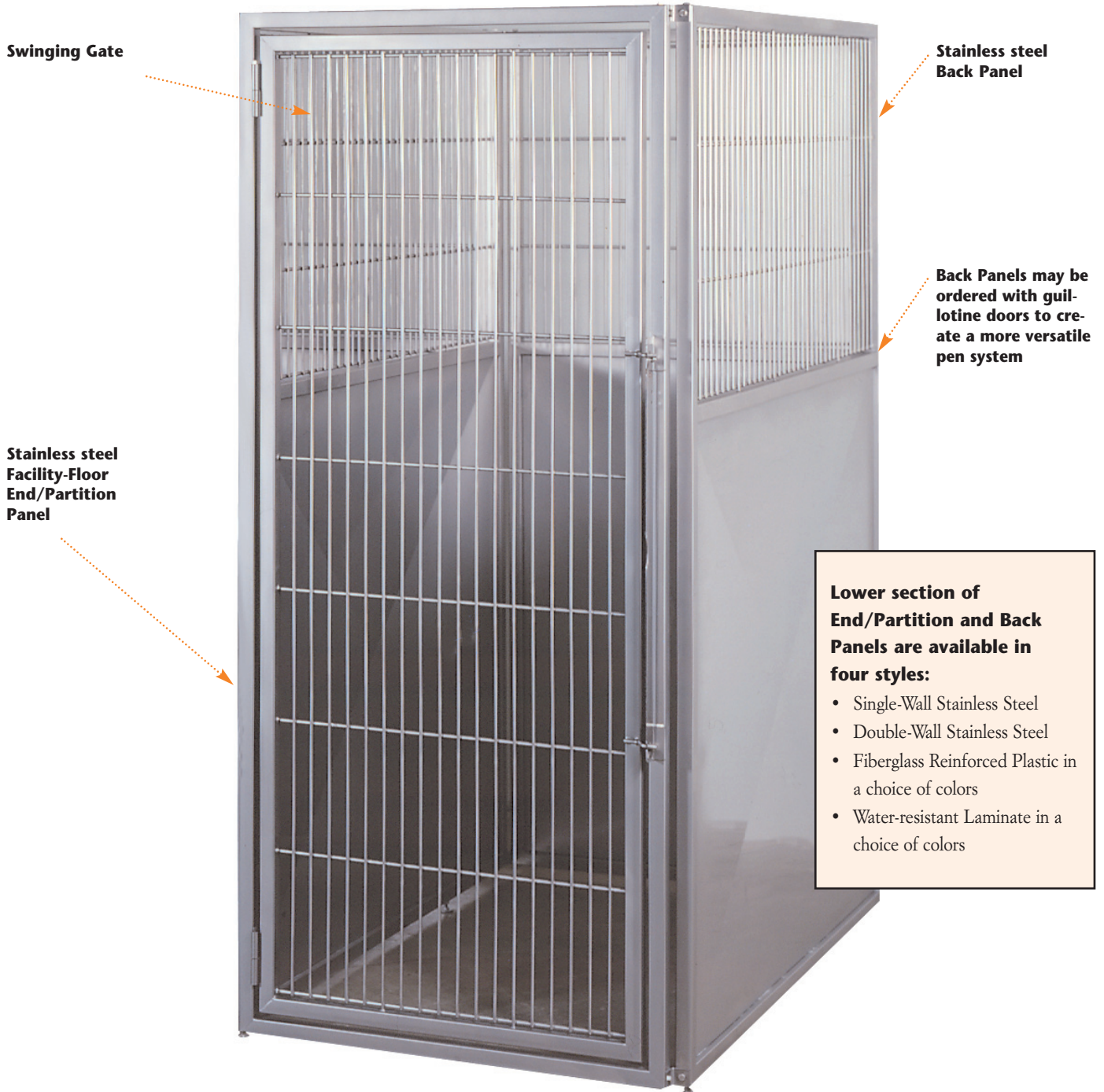

STAINLESS STEEL RAISED-FLOOR SYSTEMS

Our Raised-floor Pen System allows fluids and debris to fall through to the facility floor to keep the animals in your care drier and more comfortable. Expanded metal Floor Sections have bright plastisol coating to make debris more visible and encourage kennel staff to keep pens cleaner, more sanitary. Full-length Floor-support Brackets or Rings built into Partition and End Panels keep Floor Sections completely stable at all times.

This system uses six components to create a totally free-standing pen system: Swinging Gates, Left Partition Panels,

Right Partition Panels, End Panels, Back Panels and Coated Floor Sections.

If your pen system uses your facility's walls for the back, Back Panels can be eliminated. If you use facility walls for one or both ends of your pen system, End Panels may be eliminated, and you will need to order Wall-mount Floor support Brackets or Rings.

SRF

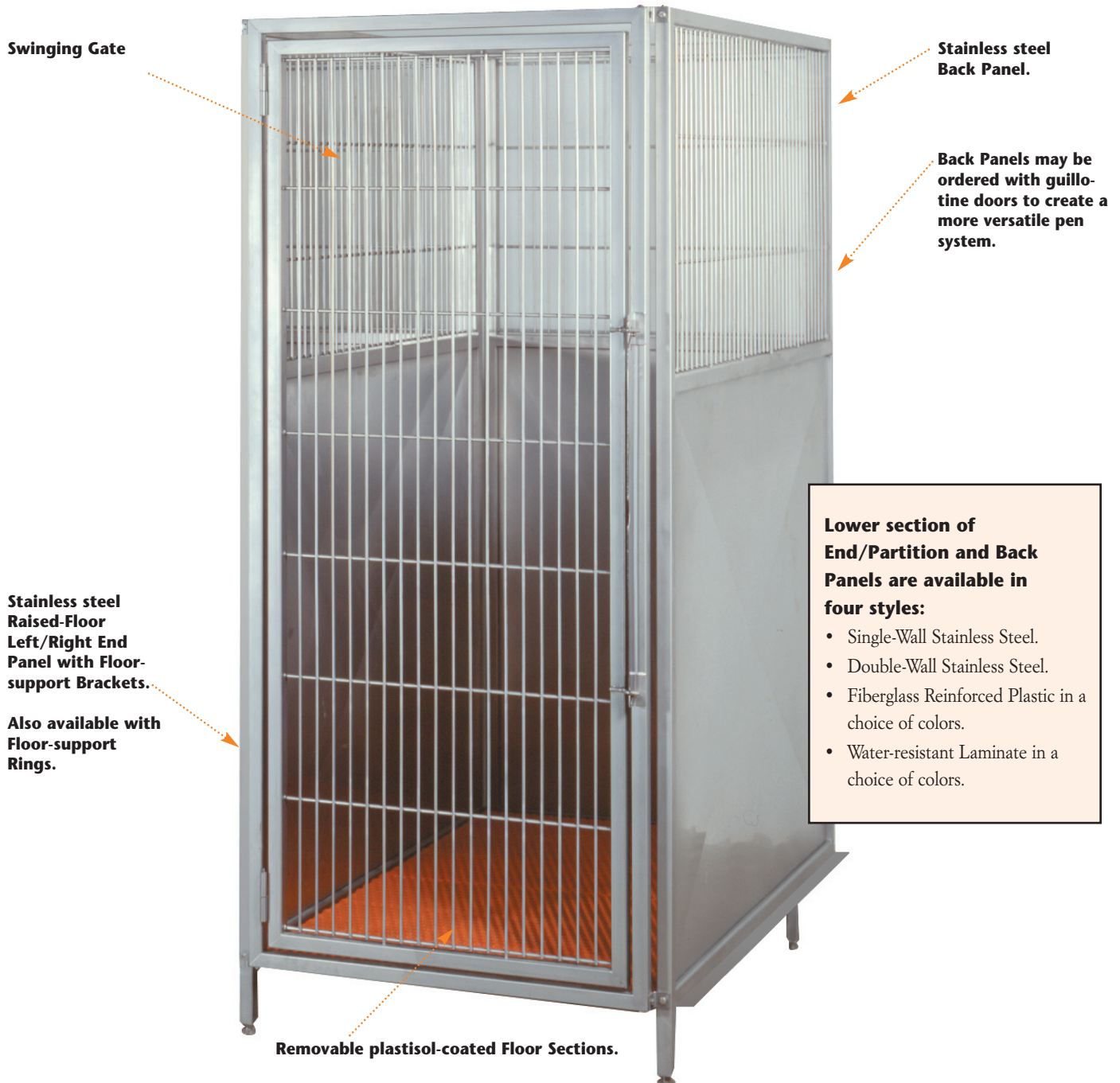

Total Animal Pen Systems

MFF

MASONRY FACILITY-FLOOR SYSTEMS

Our stainless steel modular components are uniquely designed to work just as well with masonry walls. This system uses four main components: masonry lower partition, end and back walls; stainless steel Swinging Gates; stainless steel upper End/Partition Panels and; stainless steel upper Back Panels.

If you use full-height masonry back or end walls, the upper Back Panels and one or both upper End Panels can be eliminated.

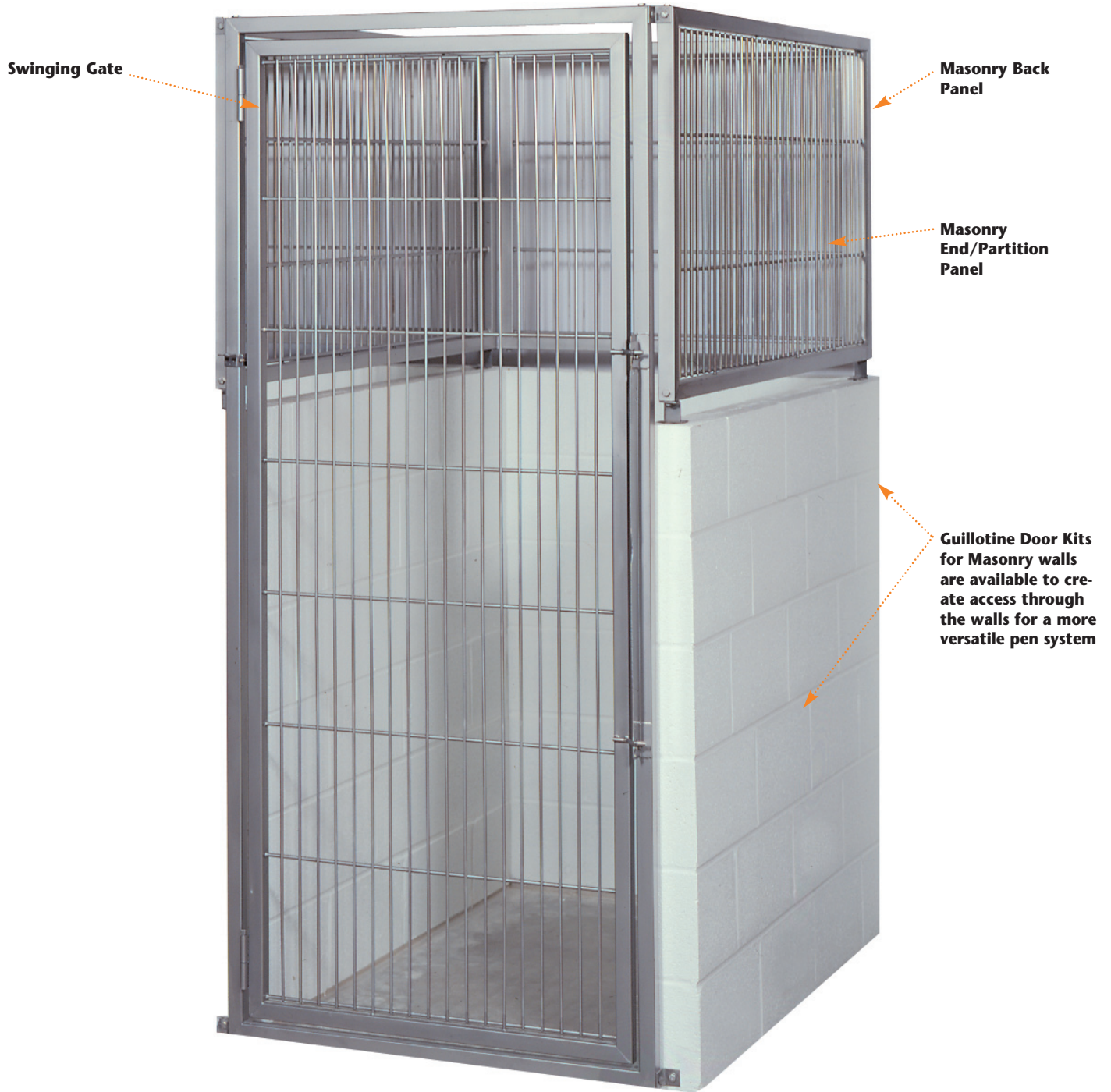

MASONRY RAISED-FLOOR SYSTEMS

Our Raised-floor Masonry Pen System allows fluids and debris to fall through to the facility floor to keep the animals in your care drier and more comfortable. Expanded metal Floor Sections have bright plastisol coating to make debris more visible and encourage kennel staff to keep pens cleaner, more sanitary. Wall-mounted Floor-support Brackets or Rings keep Floor Sections completely stable at all times.

This system uses six main components: masonry lower partition, end and back walls; stainless steel Swinging Gates; stainless steel upper End/Partition Panels; stainless steel upper Back Panels; removable Coated Floor Sections and wall-mounted Floor Support Brackets or Rings.

If you use full-height masonry back or end walls, the upper Back Panels and one or both upper End Panels can be eliminated.

MRF

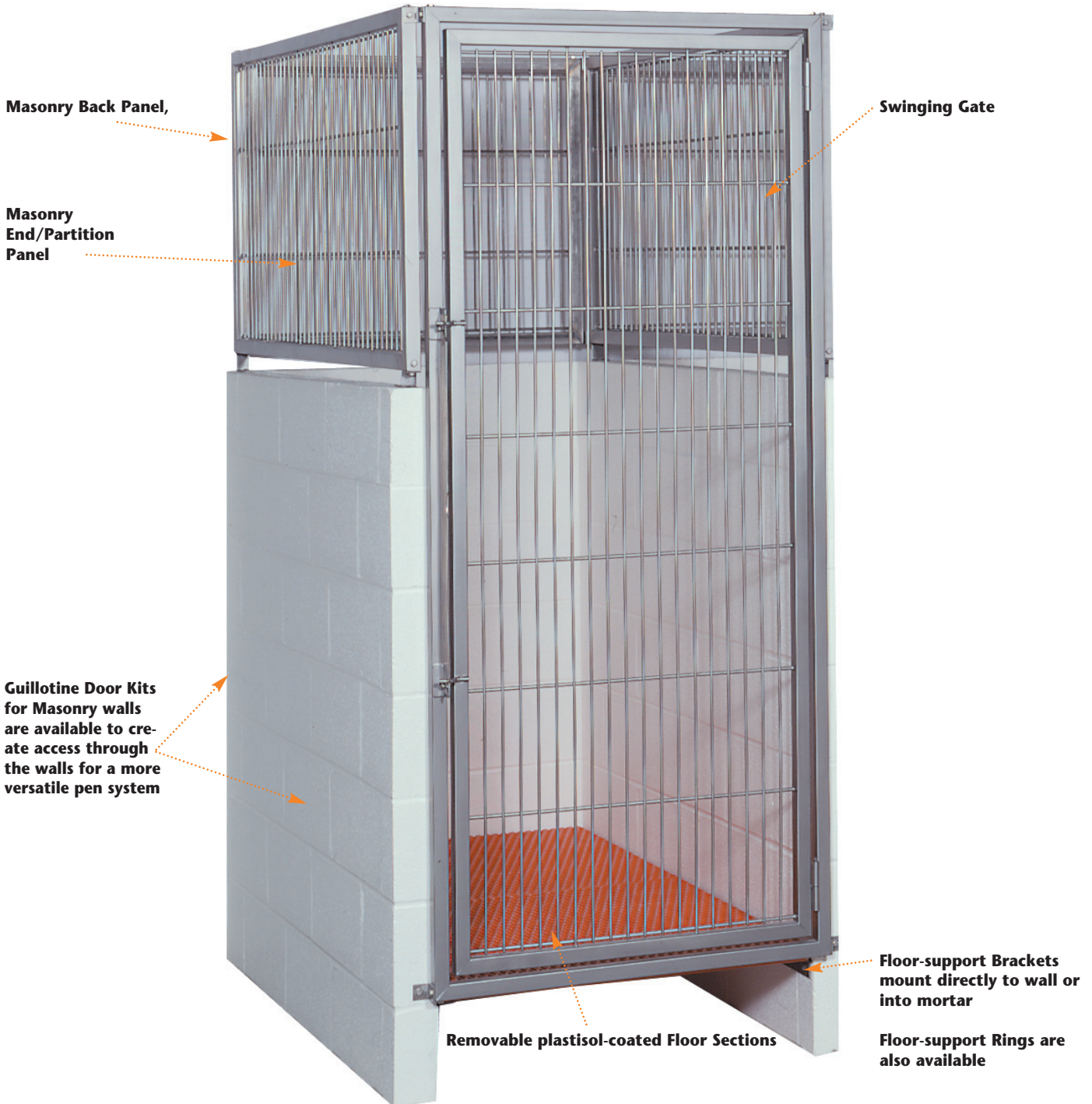

For Product Information Call TOLL-FREE 1-800-323-7366 • (847) 537-9320 • Fax (847) 537-9061
Hours: 8:30am - 5:00pm CST Monday - Friday
Visit our website at: www.suburbansurgical.com

How to Order Total Animal Pen Systems

- SFF**
- SRF**
- MFF**
- MRF**

Choose from 3 Total Pen System styles:

- SFF**= A Facility-floor Pen System with Stainless Steel Partitions.
- SRF**= A Raised-Floor Pen System with Stainless Steel Partitions.
- MFF**= A Facility-floor Pen System with Masonry Partitions.
- MRF**= A Raised-floor Pen System with Masonry Partitions

Look for this symbol on the following pages to help you choose the right components for the Pen System you desire.

HOW TO BUILD THE PERFECT TOTAL PEN SYSTEM FOR YOUR NEEDS:

All Total Pen Systems require a:

- Gate,
- End/Partition Panels, and
- Back Panels.

Which panels you purchase depends on the style of pen you want. Simply determine the type of Pen System you prefer from the descriptions at left, then select components from the appropriate pages as listed in the diagrams below.

1 SWINGING GATES

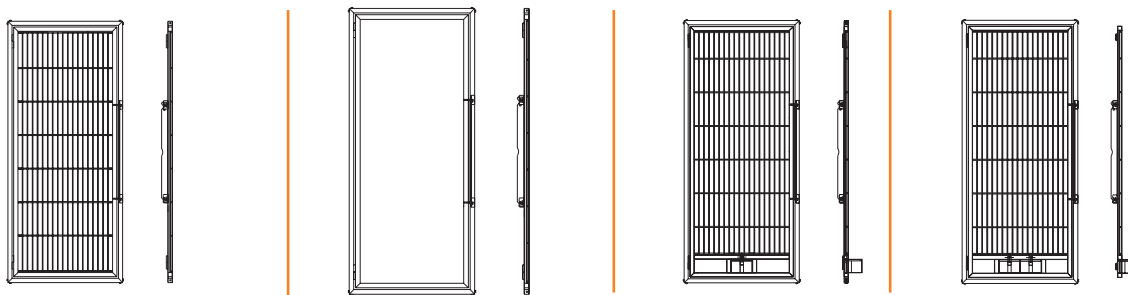

For All Styles SFF, SRF, MFF and MRF

2 END/PARTITION PANELS

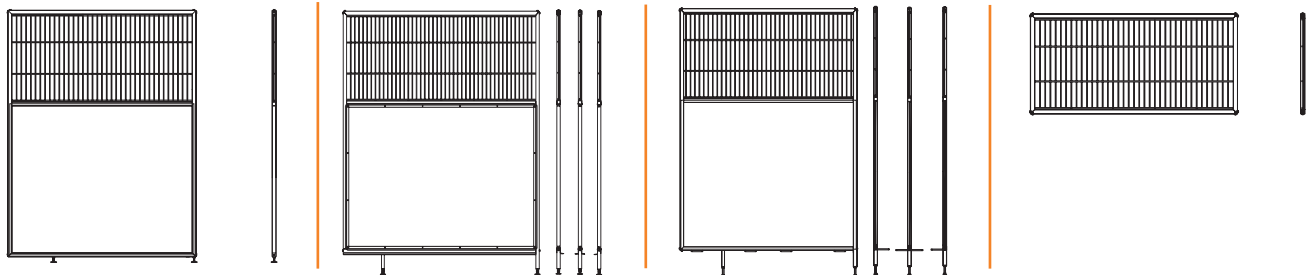

For Style SFF

With Brackets For Style SR

With Rings For Style SRF

For Style MFF and MRF

3 BACK PANELS

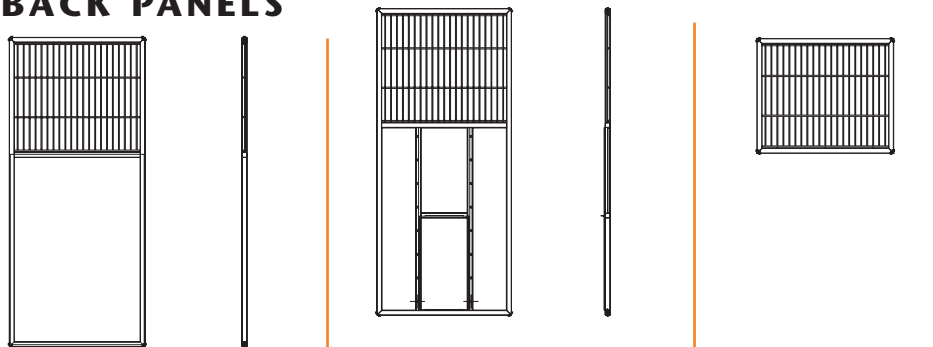

For Styles SFF and SRF

For Styles SFF and SRF

For Styles MFF and MRF

Swinging Gates for Total Pen Systems

SWINGING GATES WITH STAINLESS STEEL GRILL FOR ALL TOTAL PEN SYSTEMS

Our exclusive features ensure your Total Animal Pen System Gates will operate smoothly for years to come. Stainless steel grill is welded at all contact points to eliminate racking, shifting and rattling. Fully welded design prevents fluids from seeping into frame to make our Pen Systems the most sanitary pens you can buy.

SFF
SRF
MFF
MRF

Frame

Gate jamb and frame are made of 18-gauge-1.25-in. (3.17cm) square Type 304 stainless steel tubing with uniform, non-glare finish.

All corners have weldnut welded to the inside of the tubing to allow you to disassemble and reassemble pens without loss of structural integrity.

Mitered corners and heli-arc welded joints on gate jamb and frame seal out fluids and debris.

Gate features a uniform, non-glare, easy-to-clean finish.

Grill

Grill is fully circumference welded to the tubular frame at all contact points to eliminate shifting, racking and rattling, and prevent fluids from entering the frame.

Vertical spokes are made of .2375-in. (.603cm) diameter stainless steel.

Crossmembers are made of .312-in. (.792cm) diameter stainless steel.

Stainless steel vertical spokes and crossmembers are welded together at every intersection.

Latch

Heavy 12-gauge stainless steel latch brackets are adjustable for smooth, secure operation.

Heavy 12-gauge stainless steel latch connector secures the gate at two point 31-in. (78.74cm). More secure than gates with only one latch in the center.

Latch connector disassembles easily for cleaning and adjustments.

Latch connector is designed to accommodate a padlock for extra safety.

Hinges

Stainless steel .3125-in. diameter (.79cm) hinge pins remove easily for simple maintenance if necessary.

Durable heavy 12-gauge stainless steel barrel hinges are welded to the swinging gate jamb and frame for smooth operation.

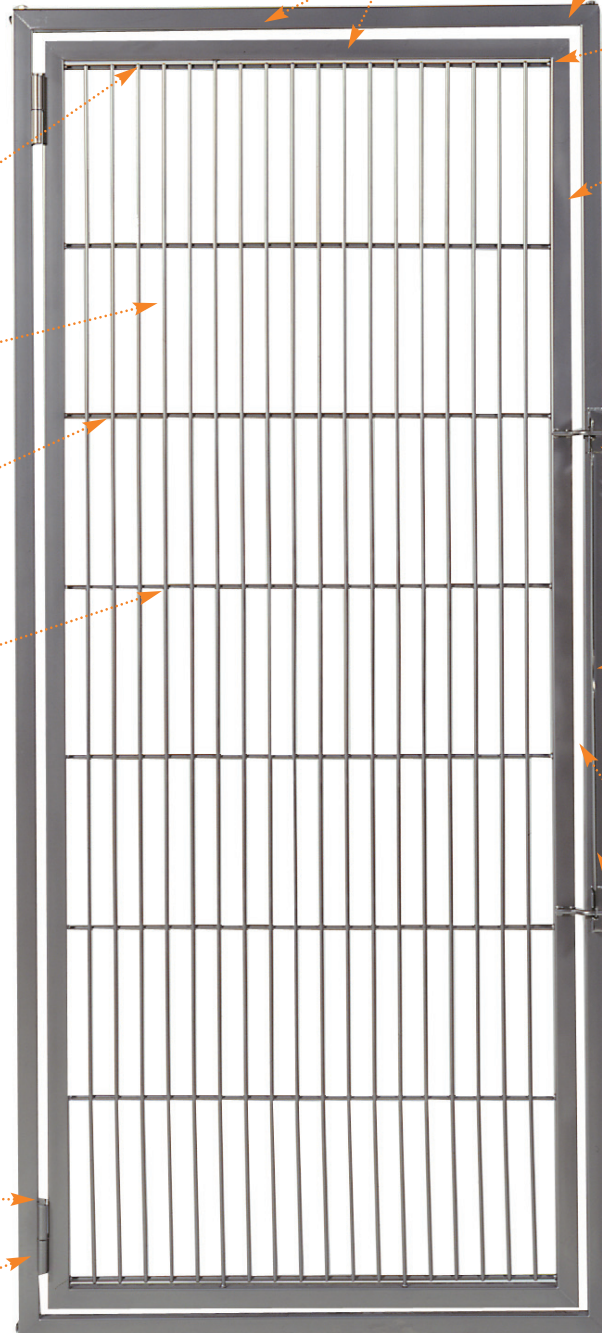

Swinging Gates for Total Pen Systems

SFF
SRF
MFF
MRF

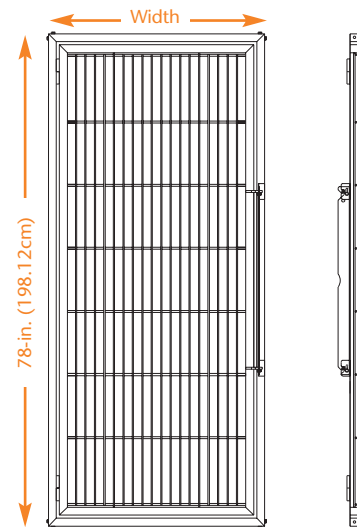

Observation Swinging Gate with Stainless Steel Grill

Tubular stainless steel gate jamb and frame with a full-height grill has uniform, non-glare finish. May be installed to latch right or left. Gates measure 78-in. (198.12cm) high.

P/N	WIDTH	
	Inches	Centimeters
AAAAOZ1A780002825AAA	28.25W	71.75W
AAAAOZ1A780003125AAA	31.25W	79.37W
AAAAOZ1A780003425AAA	34.25W	87.00W
AAAAOZ1A780003725AAA	37.25W	94.61W
AAAAOZ1A780004025AAA	40.25W	102.23W
AAAAOZ1A780004325AAA	43.25W	109.85W
AAAAOZ1A780004625AAA	46.25W	117.48W

Swinging Gates for Total Pen Systems

Swinging Gates with Built-in Bowl Holders

Tubular stainless steel frame and gate with built-in bowl holders at the bottom. Stainless steel 1.5-quart (1.42-liter) bowls slide out to simplify feeding. Order a left or right latching gate to meet your needs. Gates measure 78-in. (198.12cm) high overall. Bowls sold separately below.

SFF
SRF
MFF
MRF

Designed with the same high quality heavy-duty stainless steel features as our Swinging Gate with Stainless steel Grill.

Stainless steel feeding bowls slide out and latch in place to simplify feeding the animals in your care.

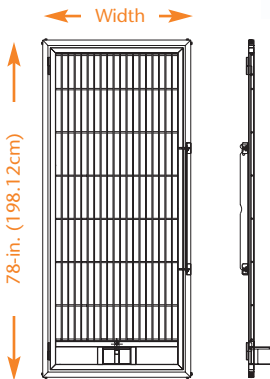

With one Bowl Holder

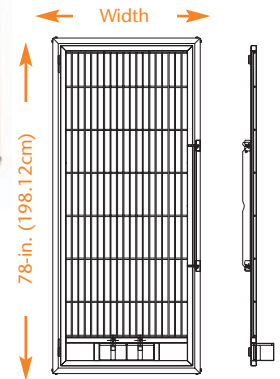

With two Bowl Holders

P/N	Latches	WIDTH	
		Inches	Centimeters
AAAA0Z1A780002825RFE	Left	28.25W	71.75W
AAAB0Z1A780002825RFE	Right	28.25W	71.75W
AAAA0Z1A780003125RFE	Left	31.25W	79.37W
AAAB0Z1A780003125RFE	Right	31.25W	79.37W
AAAA0Z1A780003425RFE	Left	34.25W	87.00W
AAAB0Z1A780003425RFE	Right	34.25W	87.00W
AAAA0Z1A780003725RFE	Left	37.25W	94.61W
AAAB0Z1A780003725RFE	Right	37.25W	94.61W
AAAA0Z1A780004025RFE	Left	40.25W	102.23W
AAAB0Z1A780004025RFE	Right	40.25W	102.23W
AAAA0Z1A780004325RFE	Left	43.25W	109.85W
AAAB0Z1A780004325RFE	Right	43.25W	109.85W
AAAA0Z1A780004625RFE	Left	46.25W	117.48W
AAAB0Z1A780004625RFE	Right	46.25W	117.48W
Stainless Steel Bowl			
12308-00-A5AAAA	1.5 Quarts (1.42 Liters)		

P/N	Latches	WIDTH	
		Inches	Centimeters
AAAA0Z1A780002825RFD	Left	28.25W	71.75W
AAAB0Z1A780002825RFD	Right	28.25W	71.75W
AAAA0Z1A780003125RFD	Left	31.25W	79.37W
AAAB0Z1A780003125RFD	Right	31.25W	79.37W
AAAA0Z1A780003425RFD	Left	34.25W	87.00W
AAAB0Z1A780003425RFD	Right	34.25W	87.00W
AAAA0Z1A780003725RFD	Left	37.25W	94.61W
AAAB0Z1A780003725RFD	Right	37.25W	94.61W
AAAA0Z1A780004025RFD	Left	40.25W	102.23W
AAAB0Z1A780004025RFD	Right	40.25W	102.23W
AAAA0Z1A780004325RFD	Left	43.25W	109.85W
AAAB0Z1A780004325RFD	Right	43.25W	109.85W
AAAA0Z1A780004625RFD	Left	46.25W	117.48W
AAAB0Z1A780004625RFD	Right	46.25W	117.48W
Stainless Steel Bowl			
12308-00-A5AAAA	1.5 Quarts (1.42 Liters)		

For Product Information Call TOLL-FREE 1-800-323-7366 • (847) 537-9320 • Fax (847) 537-9061
Hours: 8:30am - 5:00pm CST Monday - Friday
 Visit our website at: www.suburbansurgical.com

Swinging Gates for Total Pen Systems

SFF
SRF
MFF
MRF



Designed with the same high quality heavy-duty stainless steel features as our Swinging Gate with Stainless steel Grill.

Full-height tempered glass panel allows complete view of inside of pen.

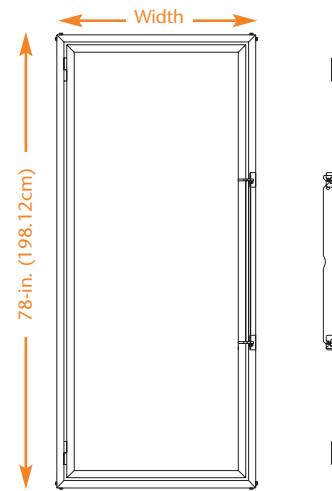

Observation Swinging Gate with Tempered Glass Panel Insert

Full-view tempered glass offers an unobstructed view of the pen. Tubular stainless steel gate jamb and frame has uniform, non-glare finish. May be installed to latch right or left. Gates measure 78-in. (198.12cm) high.

P/N	WIDTH	
	Inches	Centimeters
AAAA0Z1N780002825GSA	28.25W	71.75W
AAAA0Z1N780003125GSA	31.25W	79.37W
AAAA0Z1N780003425GSA	34.25W	87.00W
AAAA0Z1N780003725GSA	37.25W	94.61W
AAAA0Z1N780004025GSA	40.25W	102.23W
AAAA0Z1N780004325GSA	43.25W	109.85W
AAAA0Z1N780004625GSA	46.25W	117.48W

End/Partition Panels for Stainless Steel Facility-Floor Pen Systems

END/PARTITION PANELS FOR STAINLESS STEEL FACILITY-FLOOR PENS

SFF

High-quality stainless steel panels fit precisely with our other components for a safe, secure installation in minimal time. Our panels are constructed with a stainless steel upper grill and a solid lower panel in your choice of four styles. Leveling feet adjust to accommodate any irregularities in your floors.

Optional floor seal kits effectively eliminate contamination between pens.

Order one panel for each partition between pens, and one panel for each end of your Pen System if you are not using your facility's walls. For stability, we recommend Back Panels for all systems not anchored to masonry walls.

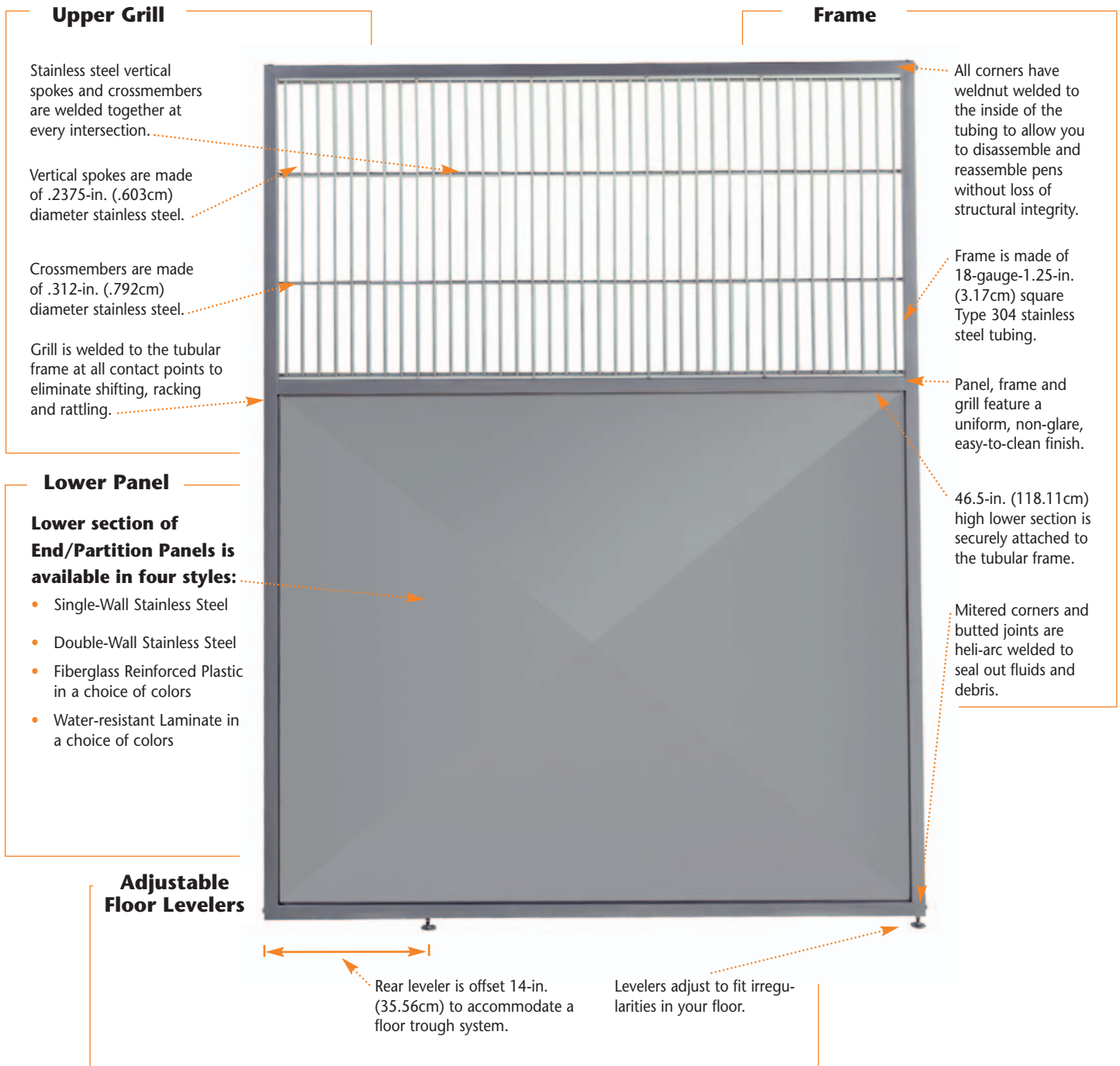

End/Partition Panels for Stainless Steel Facility-Floor Standing Pen Systems

SFF

Single-Wall lower section is tack-welded to the frame.

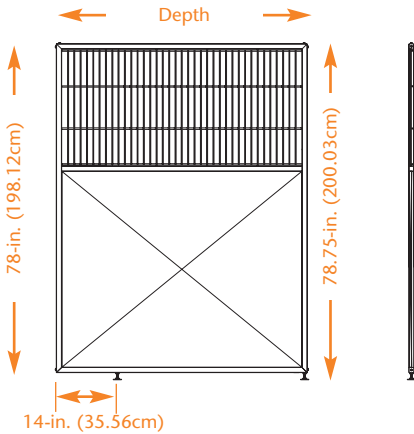
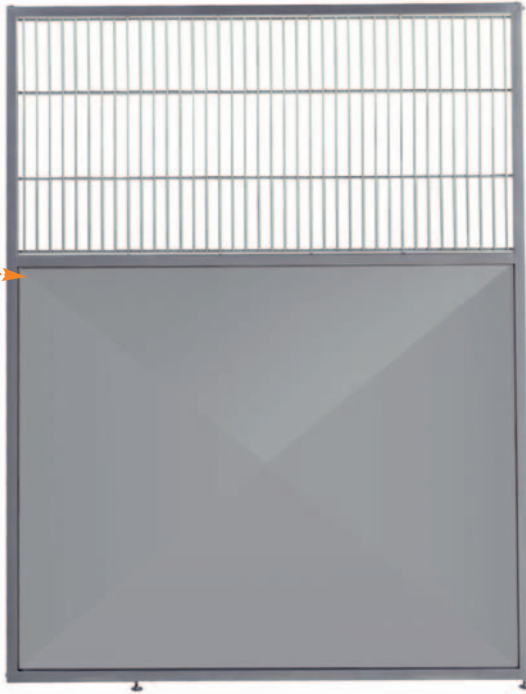

Stainless Steel Single-Wall End/Partition Panels

The most sanitary, longest lasting partition panel we sell. Single-ly, 46.5-in. (118.11cm) high stainless steel lower panel is tack welded to the tubular stainless steel frame. Upper stainless steel grill allows you to see through Partitions into the next pen. Designed for level floors. For sloping floors order leg level extensions. Panels measure 78.75-in. (200.03cm) high overall.

P/N	DEPTH	
	Inches	Centimeters
AA1A1A1E780004750AAA	47.50D	120.65D
AA1A1A1E780005950AAA	59.50D	151.13D
AA1A1A1E780007150AAA	71.50D	181.61D
AA1A1A1E780008350AAA	83.50D	212.09D
AA1A1A1E780009550AAA	95.50D	242.57D

Double-Wall lower section is tack-welded to the frame.

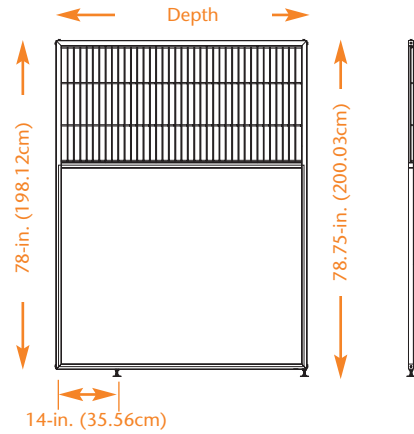

Stainless Steel Double-Wall End/Partition Panels

Sound-deadening insulation is sandwiched between two 46.5-in. (118.11cm) high stainless steel panels. Panels are tack welded to the tubular stainless steel frame. Upper stainless steel grill allows you to see through Partitions into the next pen. Designed for level floors. For sloping floors order leg level extensions. Panels measure 78.75-in. (200.03cm) high overall.

P/N	DEPTH	
	Inches	Centimeters
SALA1A1E780004750AAA	47.50D	120.65D
SALA1A1E780005950AAA	59.50D	151.13D
SALA1A1E780007150AAA	71.50D	181.61D
SALA1A1E780008350AAA	83.50D	212.09D
SALA1A1E780009550AAA	95.50D	242.57D

End/Partition Panels for Stainless Steel Facility-Floor Pen Systems

SFF

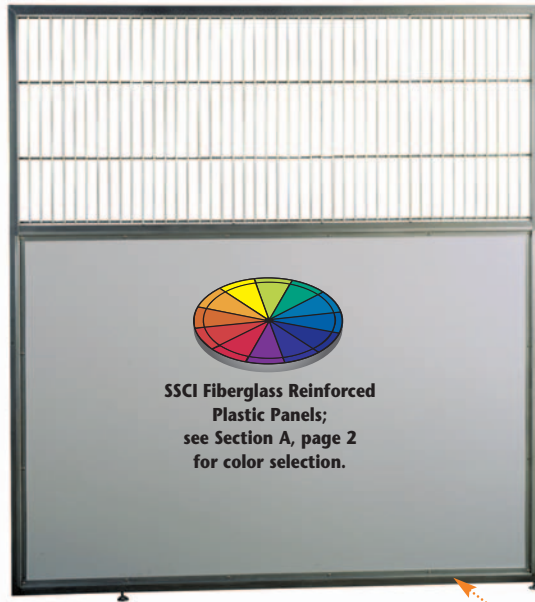

SSCI Fiberglass Reinforced Plastic Panels; see Section A, page 2 for color selection.



SSCI laminated items are available in SSCI standard colors, SSCI optional colors, or a spectrum of Customer-selected colors.

Lower section is secured to frame with stainless steel continuous die-formed brackets, machine screws and locknuts.

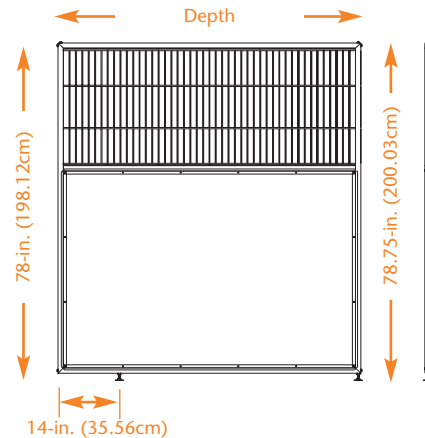
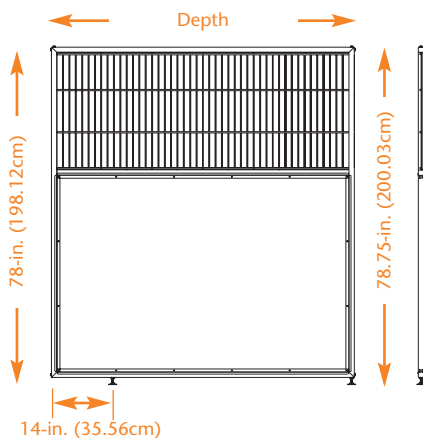

Fiberglass Reinforced Plastic End/Partition Panels

Lower corrugated-style panel is made of pebble-finish plastic reinforced with fiberglass for exceptional durability. Available in a choice of colors to brighten up your kennel. Upper stainless steel grill allows you to see through Partitions into the next pen. Panels are not guaranteed against delaminating, yet may be replaced to remain fresh and up to date. Designed for level floors. For sloping floors order leg level extensions. Panels measure 78.75-in. (200.03cm) high overall.

P/N	DEPTH	
	Inches	Centimeters
AAAL1A1Q78004750_ _ _ †	47.50D	120.65D
AAAL1A1Q78005950_ _ _ †	59.50D	151.13D
AAAL1A1Q78007150_ _ _ †	71.50D	181.61D
AAAL1A1Q78008350_ _ _ †	83.50D	212.09D
AAAL1A1Q78009550_ _ _ †	95.50D	242.57D

Laminated End/Partition Panels

Lower 46.5-in. (118.11cm) high panel features high-pressure plastic laminate over water-resistant materials in a choice of colors to match your facility décor. Upper stainless steel grill allows you to see through Partitions into the next pen. Panels are not guaranteed against delaminating, yet may be replaced to remain fresh and up to date. Designed for level floors. For sloping floors order leg level extensions. Panels measure 78.75-in. (200.03cm) high overall.

P/N	DEPTH	
	Inches	Centimeters
AAAL1A1L78004750_ _ _ †	47.50D	120.65D
AAAL1A1L78005950_ _ _ †	59.50D	151.13D
AAAL1A1L78007150_ _ _ †	71.50D	181.61D
AAAL1A1L78008350_ _ _ †	83.50D	212.09D
AAAL1A1L78009550_ _ _ †	95.50D	242.57D

Important: These customer order requirements, in addition to other customer order requirements, must be satisfied prior to the beginning of manufacturing lead time: †Specify 4-digit Color code. See Color Selections, Section A, pages 1 & 2 for Color Codes.

For Product Information Call TOLL-FREE 1-800-323-7366 • (847) 537-9320 • Fax (847) 537-9061
Hours: 8:30am - 5:00pm CST Monday - Friday
Visit our website at: www.suburbansurgical.com

Section 4

Floor Seal System for Stainless Steel Facility-Floor Pen Systems

SFF



Left Seal Strip for Sloping Floors



Right Seal Strip for Sloping Floors



Channel



Seal Strip for Level Floors



Floor Seal System

Our exclusive design is widely accepted as the most effective system for preventing migration of fluids and debris between pens in your System. The stainless steel Channel is first mechanically-fastened to your facility floor. The Panels are then set in place with the floor levelers set into the channel. A bead of silicone caulk is run along both sides of the floor channel at the floor. The angled bottom edge of the Seal Strip is positioned to cover the silicone caulk, then mechanically-fastened to the frame of the partition panels. For level floors order two Seal Strips and one Channel for each Partition Panel. For sloped floors, order one right and one left Seal Strip and one Channel for each Partition Panel.

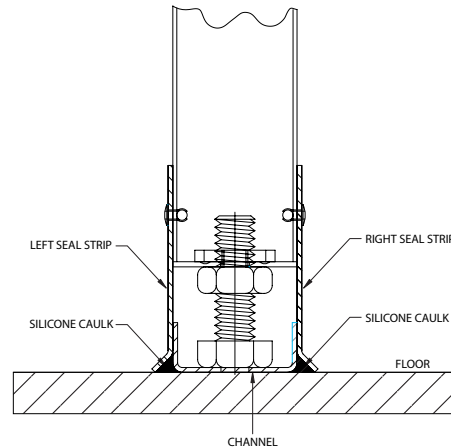

For Sloping Floors

Designed to accommodate of slope of .25-in. (.635cm) per linear foot.

P/N	POSITION	FASTENERS	FOR PENS	
			Inches	Centimeters
CUD047.500	Left	4 ST screws	47.50D	120.65D
CUE047.500	Right	4 ST Screws	47.50D	120.65D
ACUF047.500	Channel	Cement anchors	47.50D	120.65D
CUD059.500	Left	5 ST screws	59.50D	151.13D
CUE059.500	Right	5 ST screws	59.50D	151.13D
ACUF059.500	Channel	Cement anchors	59.50D	151.13D
CUD071.500	Left	6 ST screws	71.50D	181.61D
CUE071.500	Right	6 ST screws	71.50D	181.61D
ACUF071.500	Channel	Cement anchors	71.50D	181.61D
CUD083.500	Left	7 ST screws	83.50D	212.09D
CUE083.500	Right	7 ST screws	83.50D	212.09D
ACUF083.500	Channel	Cement anchors	83.50D	212.09D
CUD095.500	Left	8 ST screws	95.50D	242.57D
CUE095.500	Right	8 ST screws	95.50D	242.57D
ACUF095.500	Channel	Cement anchors	95.50D	242.57D

For Level Floors

P/N	POSITION	FASTENERS	FOR PENS	
			Inches	Centimeters
CUC047.500	Left or Right	4 ST screws	47.50D	120.65D
ACUF047.500	Channel	Cement anchors	47.50D	120.65D
CUC059.500	Left or Right	5 ST screws	59.50D	151.13D
ACUF059.500	Channel	Cement anchors	59.50D	151.13D
CUC071.500	Left or Right	6 ST screws	71.50D	181.61D
ACUF071.500	Channel	Cement anchors	71.50D	181.61D
CUC083.500	Left or Right	7 ST screws	83.50D	212.09D
ACUF083.500	Channel	Cement anchors	83.50D	212.09D
CUC095.500	Left or Right	8 ST screws	95.50D	242.57D
ACUF095.500	Channel	Cement anchors	95.50D	242.57D

End/Partition Panels for Stainless Steel Raised-Floor Pen Systems

SRF

END AND PARTITION PANELS WITH SUPPORT BRACKETS FOR STAINLESS STEEL RAISED-FLOOR PENS

High-quality panels fit precisely with our other components for a safe, secure installation in minimal time. Full-depth Floor-support Brackets hold floors securely in place. Eliminates the chance of Floor Sections tipping or rocking. Floor Sections lift for cleaning.

Panels are constructed with an upper grill and a solid lower panel in a choice of four styles. Leveling feet on extended legs accommodate irregularities in your floors.

Order one Partition Panel for each partition between pens, and one Right End and one Left End Panel for the ends of your Pen System if you are not using your facility's walls.

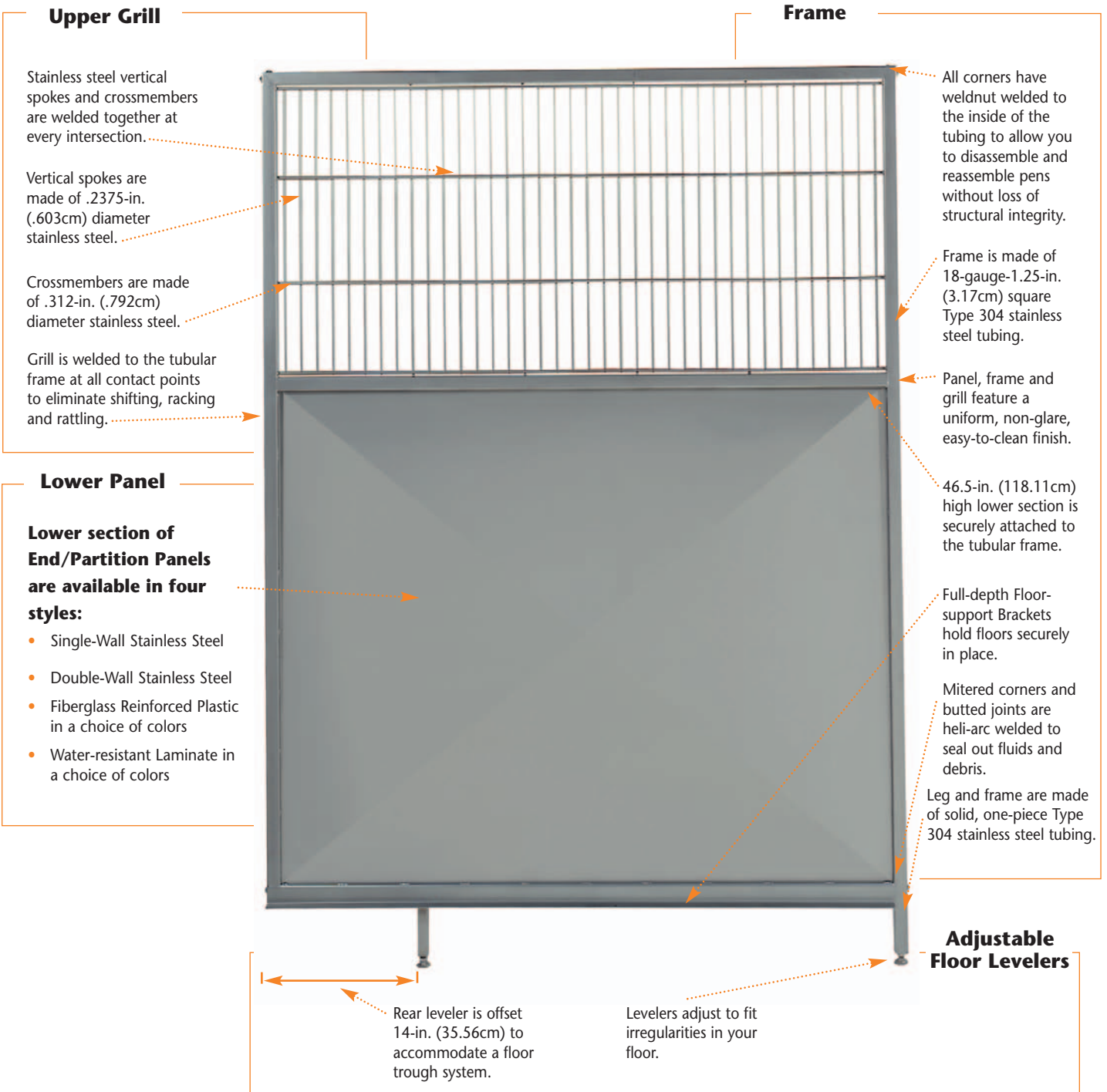

Section 4

End/Partition Panels for Stainless Steel Raised-Floor Pen Systems

SRF

Single-Wall lower section is tack-welded to the frame.

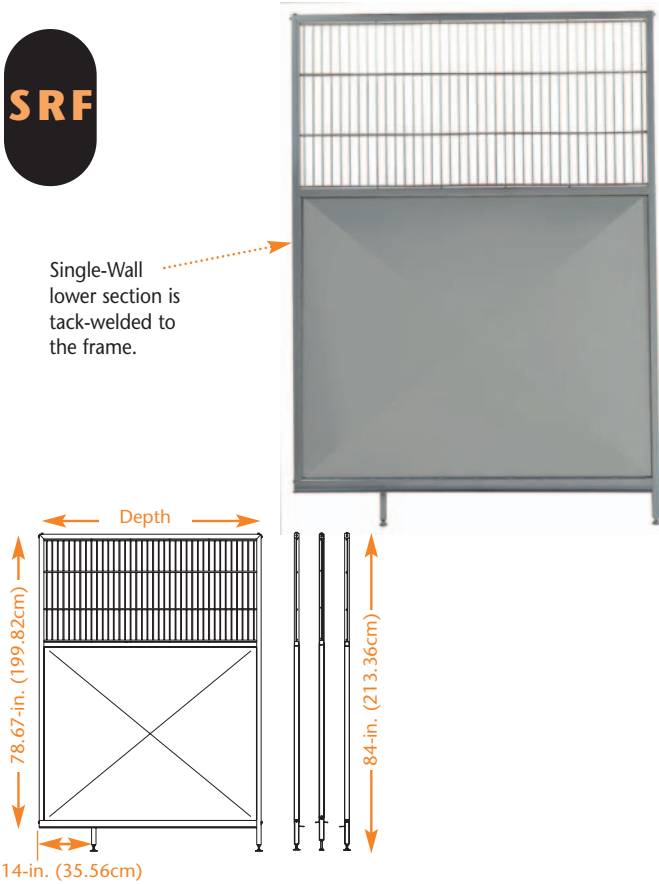

Double-Wall lower section is tack-welded to the frame.

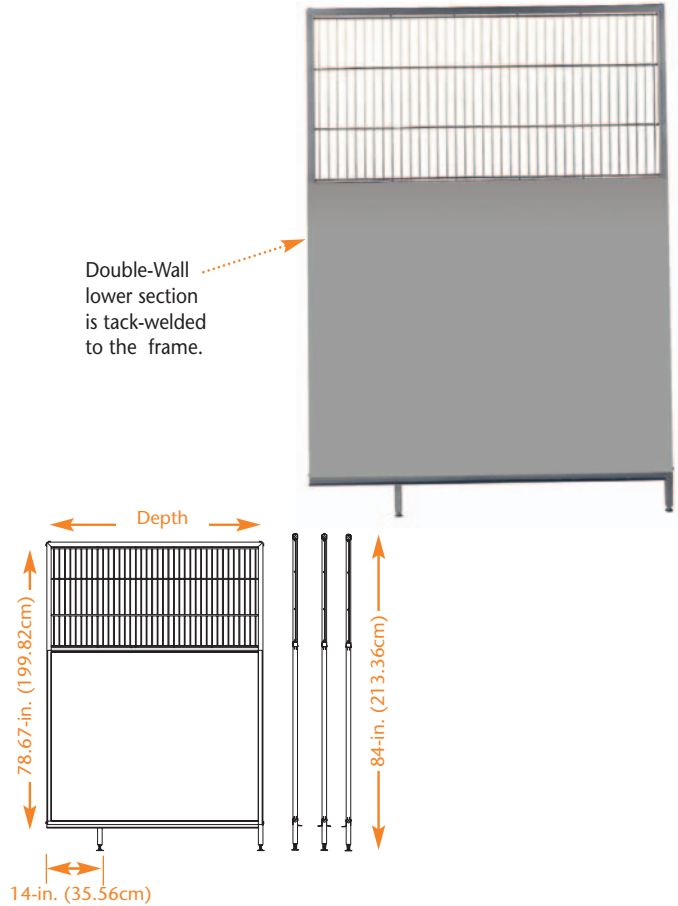

Stainless Steel Single-Wall End/Partition Panels with Support Brackets

The most sanitary, longest lasting partition panel we sell. Single-ply, 46.5-in. (118.11cm) high stainless steel lower panel is tack welded to the tubular stainless steel frame. Upper stainless steel grill allows you to see through Partitions into the next pen. Designed for level floors. For sloping floors order leg level extensions. Panels measure 84-in. (213.36cm) high overall.

Stainless Steel Double-Wall End/Partition Panels with Support Brackets

Sound-deadening insulation is sandwiched between two 46.5-in. (118.11cm) high stainless steel panels. Panels are tack welded to the tubular stainless steel frame. Upper stainless steel grill allows you to see through Partitions into the next pen. Designed for level floors. For sloping floors order leg level extensions. Panels measure 84-in. (213.36cm) high overall.

P/N	DEPTH	
	Inches	Centimeters
Right End Panels with Support Brackets		
AALC1A1E780004750AAA	47.50D	120.65D
AALC1A1E780005950AAA	59.50D	151.13D
AALC1A1E780007150AAA	71.50D	181.61D
AALC1A1E780008350AAA	83.50D	212.09D
AALC1A1E780009550AAA	95.50D	242.57D
Left End Panels with Support Brackets		
AALB1A1E780004750AAA	47.50D	120.65D
AALB1A1E780005950AAA	59.50D	151.13D
AALB1A1E780007150AAA	71.50D	181.61D
AALB1A1E780008350AAA	83.50D	212.09D
AALB1A1E780009550AAA	95.50D	242.57D
Partition Panels with Support Brackets		
AALD1A1E780004750AAA	47.50D	120.65D
AALD1A1E780005950AAA	59.50D	151.13D
AALD1A1E780007150AAA	71.50D	181.61D
AALD1A1E780008350AAA	83.50D	212.09D
AALD1A1E780009550AAA	95.50D	242.57D

P/N	DEPTH	
	Inches	Centimeters
Right End Panels with Support Brackets		
SALC1A1E780004750AAA	47.50D	120.65D
SALC1A1E780005950AAA	59.50D	151.13D
SALC1A1E780007150AAA	71.50D	181.61D
SALC1A1E780008350AAA	83.50D	212.09D
SALC1A1E780009550AAA	95.50D	242.57D
Left End Panels with Support Brackets		
SALB1A1E780004750AAA	47.50D	120.65D
SALB1A1E780005950AAA	59.50D	151.13D
SALB1A1E780007150AAA	71.50D	181.61D
SALB1A1E780008350AAA	83.50D	212.09D
SALB1A1E780009550AAA	95.50D	242.57D
Partition Panels with Support Brackets		
SALD1A1E780004750AAA	47.50D	120.65D
SALD1A1E780005950AAA	59.50D	151.13D
SALD1A1E780007150AAA	71.50D	181.61D
SALD1A1E780008350AAA	83.50D	212.09D
SALD1A1E780009550AAA	95.50D	242.57D

Section 4

End/Partition Panels for Stainless Steel Raised-Floor Pen Systems

SRF

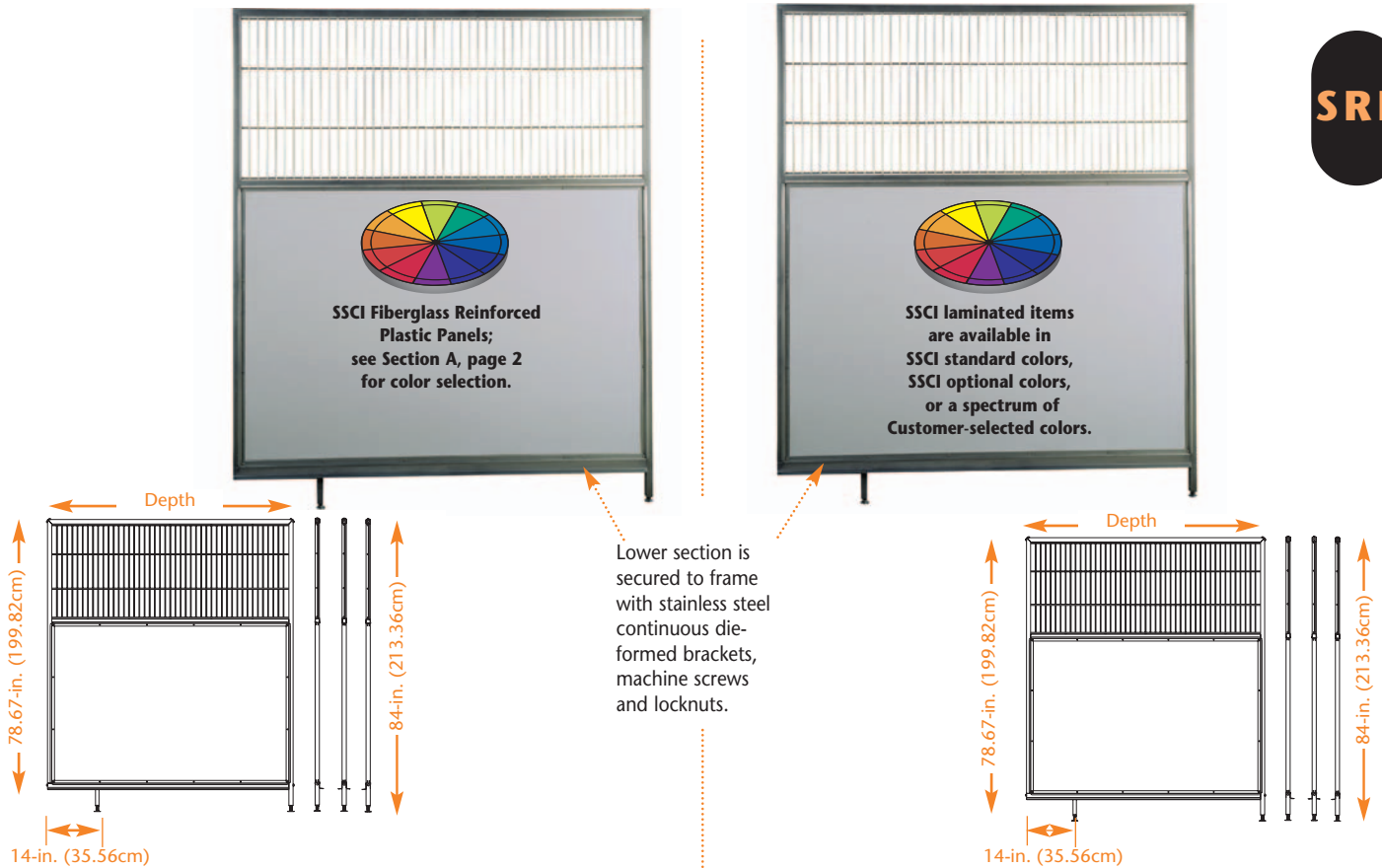

Fiberglass Reinforced Plastic End/Partition Panels with Support Brackets

Lower corrugated-style panel is made of pebble-finish plastic reinforced with fiberglass for exceptional durability. Available in a choice of colors to brighten up your kennel. Upper stainless steel grill allows you to see through Partitions into the next pen. Designed for level floors. For sloping floors order leg level extensions. Panels measure 84-in. (213.36cm) high overall.

Laminated End/Partition Panels with Support Brackets

Lower 46.5-in. (118.11cm) high panel features high-pressure plastic laminate over water-resistant materials in a choice of colors to match your facility décor. Upper stainless steel grill allows you to see through Partitions into the next pen. Panels are not guaranteed against delaminating, yet may be replaced to remain fresh and up to date. Designed for level floors. For sloping floors order leg level extensions. Panels measure 84-in. (213.36cm) high overall.

P/N	DEPTH	
	Inches	Centimeters
Right End Panels with Support Brackets		
AALC1A1Q78004750 ___ †	47.50D	120.65D
AALC1A1Q78005950 ___ †	59.50D	151.13D
AALC1A1Q78007150 ___ †	71.50D	181.61D
AALC1A1Q78008350 ___ †	83.50D	212.09D
AALC1A1Q78009550 ___ †	95.50D	242.57D
Left End Panels with Support Brackets		
AALB1A1Q78004750 ___ †	47.50D	120.65D
AALB1A1Q78005950 ___ †	59.50D	151.13D
AALB1A1Q78007150 ___ †	71.50D	181.61D
AALB1A1Q78008350 ___ †	83.50D	212.09D
AALB1A1Q78009550 ___ †	95.50D	242.57D
Partition Panels with Support Brackets		
AALD1A1Q78004750 ___ †	47.50D	120.65D
AALD1A1Q78005950 ___ †	59.50D	151.13D
AALD1A1Q78007150 ___ †	71.50D	181.61D
AALD1A1Q78008350 ___ †	83.50D	212.09D
AALD1A1Q78009550 ___ †	95.50D	242.57D

P/N	DEPTH	
	Inches	Centimeters
Right End Panels with Support Brackets		
AALC1A1L78004750 ___ †	47.50D	120.65D
AALC1A1L78005950 ___ †	59.50D	151.13D
AALC1A1L78007150 ___ †	71.50D	181.61D
AALC1A1L78008350 ___ †	83.50D	212.09D
AALC1A1L78009550 ___ †	95.50D	242.57D
Left End Panels with Support Brackets		
AALB1A1L78004750 ___ †	47.50D	120.65D
AALB1A1L78005950 ___ †	59.50D	151.13D
AALB1A1L78007150 ___ †	71.50D	181.61D
AALB1A1L78008350 ___ †	83.50D	212.09D
AALB1A1L78009550 ___ †	95.50D	242.57D
Partition Panels with Support Brackets		
AALD1A1L78004750 ___ †	47.50D	120.65D
AALD1A1L78005950 ___ †	59.50D	151.13D
AALD1A1L78007150 ___ †	71.50D	181.61D
AALD1A1L78008350 ___ †	83.50D	212.09D
AALD1A1L78009550 ___ †	95.50D	242.57D

Important: These customer order requirements, in addition to other customer order requirements, must be satisfied prior to the beginning of manufacturing lead time: †Specify 4-digit Color code. See Color Selections, Section A, pages 1 & 2 for Color Codes.

For Product Information Call TOLL-FREE 1-800-323-7366 • (847) 537-9320 • Fax (847) 537-9061
Hours: 8:30am - 5:00pm CST Monday - Friday
 Visit our website at: www.suburbansurgical.com

End/Partition Panels for Stainless Steel Raised-Floor Pen Systems

SRF

END AND PARTITION PANELS WITH SUPPORT RINGS FOR STAINLESS STEEL RAISED-FLOOR PENS

High-quality panels fit precisely with our other components for a safe, secure installation in minimal time. Stainless steel Floor-support Rings offer positive floor support with cleaning efficiency. Floor Sections lift up and rest on rings for cleaning. Panels are constructed with an upper grill and a solid lower

panel in a choice of four styles. Leveling feet on extended legs accommodate irregularities in your floors.

Order one Partition Panel for each partition between pens, and one Right End and one Left End Panel for the ends of your Pen System if you are not using your facility's walls.

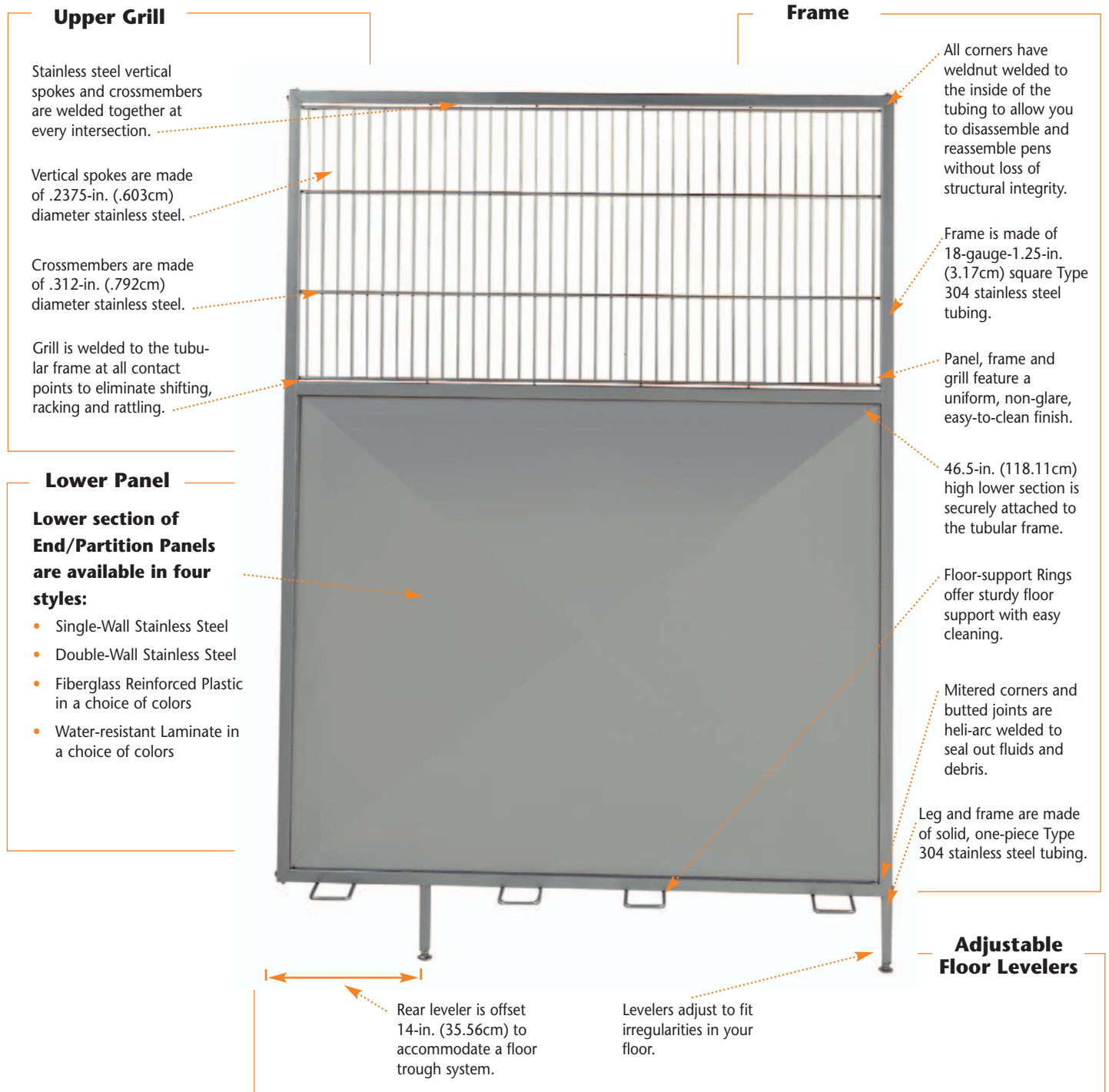

End/Partition Panels for Stainless Steel Raised-Floor Pen Systems

SRF

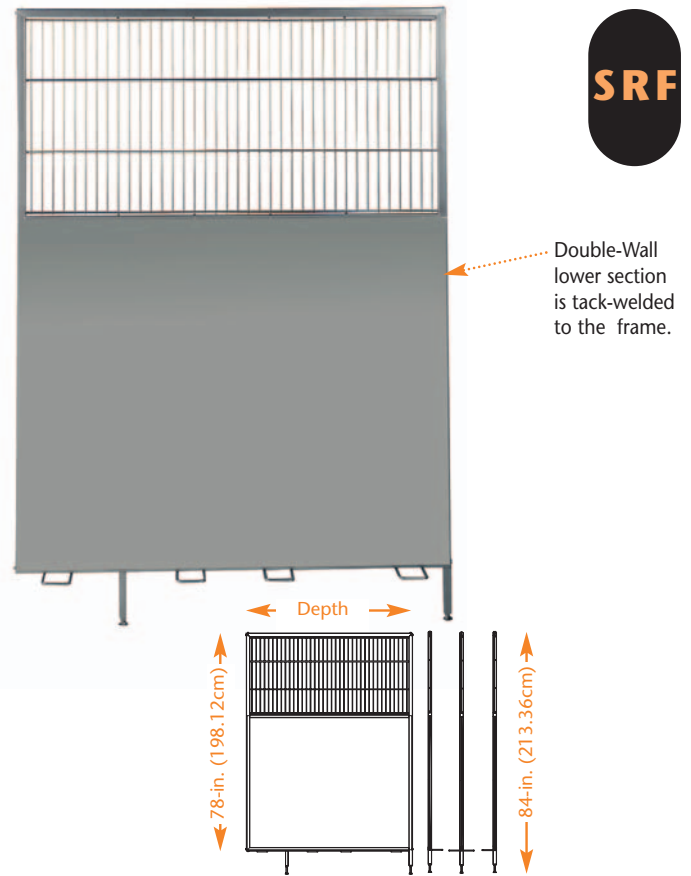
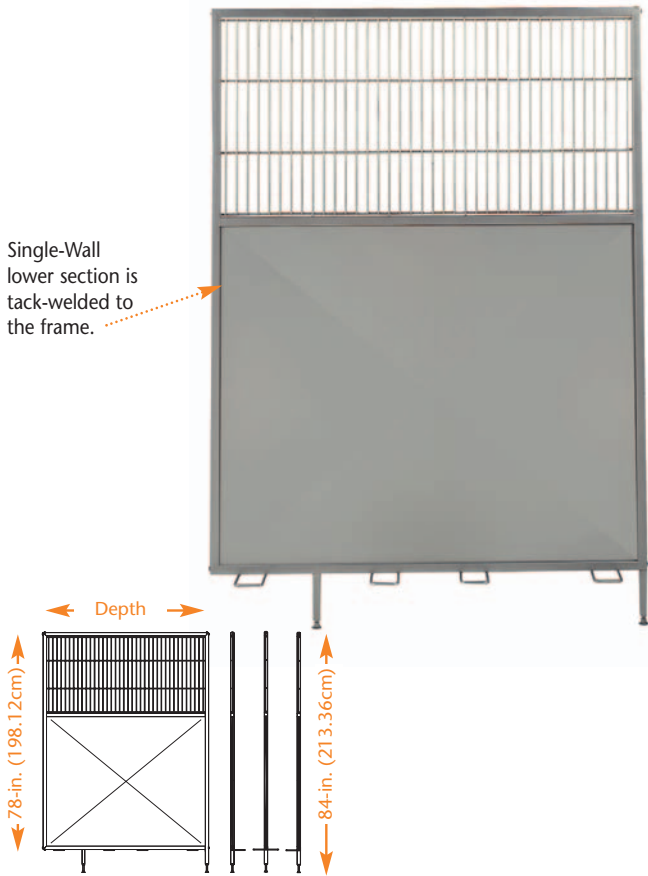

Stainless Steel Single-Wall End/Partition Panels with Support Rings

The most sanitary, longest lasting partition we sell. Single-ply, 46.5-in. (118.11cm) high stainless steel lower panel is tack welded to the tubular stainless steel frame. Upper stainless steel grill allows you to see through Partitions into the next pen. Designed for level floors. For sloping floors order leg level extensions. Panels measure 84-in. (213.36cm) high overall.

Stainless Steel Double-Wall End/Partition Panels with Support Rings

Sound-deadening insulation is sandwiched between two 46.5-in. (118.11cm) high stainless steel panels. Panels are tack welded to the tubular stainless steel frame. Upper stainless steel grill allows you to see through Partitions into the next pen. Designed for level floors. For sloping floors order leg level extensions. Panels measure 84-in. (213.36cm) high overall.

P/N	DEPTH	
	Inches	Centimeters
Right End Panels with Support Rings		
MALC1A1E780004750AAA	47.50D	120.65D
MALC1A1E780005950AAA	59.50D	151.13D
MALC1A1E780007150AAA	71.50D	181.61D
MALC1A1E780008350AAA	83.50D	212.09D
MALC1A1E780009550AAA	95.50D	242.57D
Left End Panels with Support Rings		
MALB1A1E780004750AAA	47.50D	120.65D
MALB1A1E780005950AAA	59.50D	151.13D
MALB1A1E780007150AAA	71.50D	181.61D
MALB1A1E780008350AAA	83.50D	212.09D
MALB1A1E780009550AAA	95.50D	242.57D
Partition Panels with Support Rings		
MALD1A1E780004750AAA	47.50D	120.65D
MALD1A1E780005950AAA	59.50D	151.13D
MALD1A1E780007150AAA	71.50D	181.61D
MALD1A1E780008350AAA	83.50D	212.09D
MALD1A1E780009550AAA	95.50D	242.57D

P/N	DEPTH	
	Inches	Centimeters
Right End Panels with Support Rings		
WALC1A1E780004750AAA	47.50D	120.65D
WALC1A1E780005950AAA	59.50D	151.13D
WALC1A1E780007150AAA	71.50D	181.61D
WALC1A1E780008350AAA	83.50D	212.09D
WALC1A1E780009550AAA	95.50D	242.57D
Left End Panels with Support Rings		
WALB1A1E780004750AAA	47.50D	120.65D
WALB1A1E780005950AAA	59.50D	151.13D
WALB1A1E780007150AAA	71.50D	181.61D
WALB1A1E780008350AAA	83.50D	212.09D
WALB1A1E780009550AAA	95.50D	242.57D
Partition Panels with Support Rings		
WALD1A1E780004750AAA	47.50D	120.65D
WALD1A1E780005950AAA	59.50D	151.13D
WALD1A1E780007150AAA	71.50D	181.61D
WALD1A1E780008350AAA	83.50D	212.09D
WALD1A1E780009550AAA	95.50D	242.57D

End/Partition Panels for Stainless Steel Raised-Floor Pen Systems

SRF

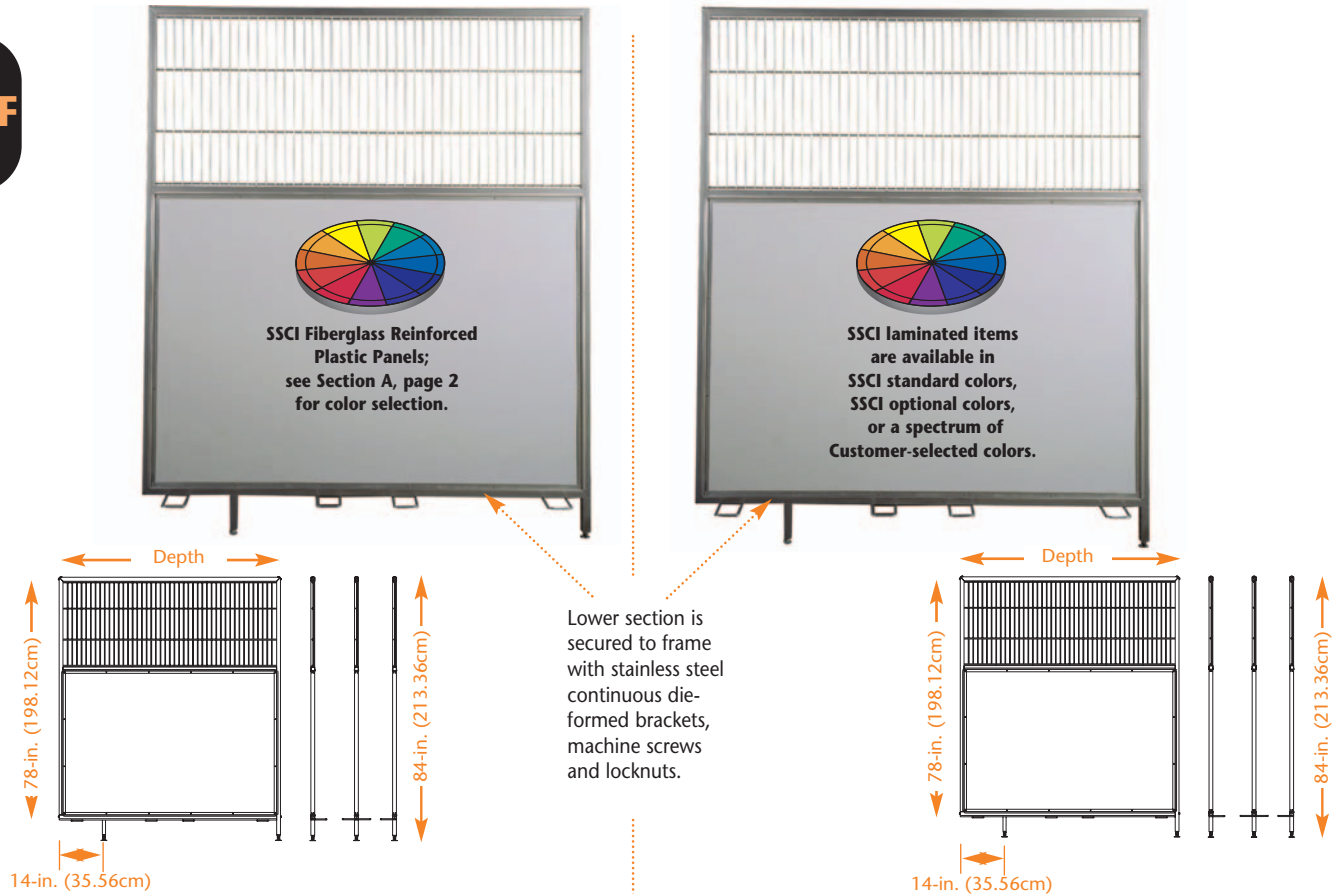

Fiberglass Reinforced Plastic End/Partition Panels with Support Rings

Lower corrugated-style panel is made of pebble-finish plastic reinforced with fiberglass for exceptional durability. Available in a choice of colors to brighten up your kennel. Upper stainless steel grill allows you to see through Partitions into the next pen. Designed for level floors. For sloping floors order leg level extensions. Panels measure 84-in. (213.36cm) high overall.

Laminated End/Partition Panels with Support Rings

Lower 46.5-in. (118.11cm) high panel features high-pressure plastic laminate over water-resistant materials in a choice of colors to match your facility décor. Upper stainless steel grill allows you to see through Partitions into the next pen. Panels are not guaranteed against delaminating, yet may be replaced to remain fresh and up to date. Designed for level floors. For sloping floors order leg level extensions. Panels measure 84-in. (213.36cm) high overall.

P/N	DEPTH	
	Inches	Centimeters
Right End Panels with Support Rings		
MALC1A1Q78004750___†	47.50D	120.65D
MALC1A1Q78005950___†	59.50D	151.13D
MALC1A1Q78007150___†	71.50D	181.61D
MALC1A1Q78008350___†	83.50D	212.09D
MALC1A1Q78009550___†	95.50D	242.57D
Left End Panels with Support Rings		
MALB1A1Q78004750___†	47.50D	120.65D
MALB1A1Q78005950___†	59.50D	151.13D
MALB1A1Q78007150___†	71.50D	181.61D
MALB1A1Q78008350___†	83.50D	212.09D
MALB1A1Q78009550___†	95.50D	242.57D
Partition Panels with Support Rings		
MALD1A1Q78004750___†	47.50D	120.65D
MALD1A1Q78005950___†	59.50D	151.13D
MALD1A1Q78007150___†	71.50D	181.61D
MALD1A1Q78008350___†	83.50D	212.09D
MALD1A1Q78009550___†	95.50D	242.57D

P/N	DEPTH	
	Inches	Centimeters
Right End Panels with Support Rings		
MALC1A1L78004750___†	47.50D	120.65D
MALC1A1L78005950___†	59.50D	151.13D
MALC1A1L78007150___†	71.50D	181.61D
MALC1A1L78008350___†	83.50D	212.09D
MALC1A1L78009550___†	95.50D	242.57D
Left End Panels with Support Rings		
MALB1A1L78004750___†	47.50D	120.65D
MALB1A1L78005950___†	59.50D	151.13D
MALB1A1L78007150___†	71.50D	181.61D
MALB1A1L78008350___†	83.50D	212.09D
MALB1A1L78009550___†	95.50D	242.57D
Partition Panels with Support Rings		
MALD1A1L78004750___†	47.50D	120.65D
MALD1A1L78005950___†	59.50D	151.13D
MALD1A1L78007150___†	71.50D	181.61D
MALD1A1L78008350___†	83.50D	212.09D
MALD1A1L78009550___†	95.50D	242.57D

Important: These customer order requirements, in addition to other customer order requirements, must be satisfied prior to the beginning of manufacturing lead time: †Specify 4-digit Color code. See Color Selections, Section A, pages 1 & 2 for Color Codes.

Coated Floors for Stainless Steel Raised-Floor Pen Systems

SRF

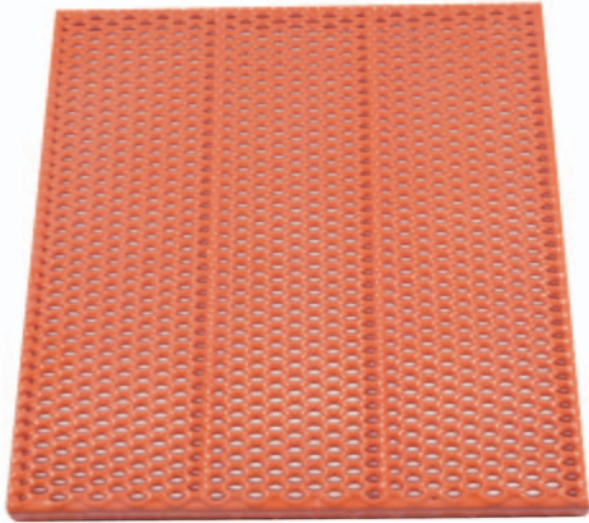

Coated Floor Sections

Super strong expanded metal Floor Sections have a plastisol coating for warmth and comfort, as well as for easy cleaning. Waste fluids fall through the grate to the facility floor to be hosed away. Bright color makes debris more visible to encourage your kennel staff to keep pens more sanitary while animals are in your care.

Sections lift for a thorough cleaning with Hook sold separately below. Refer to chart below for the number of Floor Sections required to fit your Pens.

P/N	FOR PENS		SECTIONS NEEDED
	Inches	Centimeters	
AAA28.250-023.812AA	28.25W x 47.50D	71.75W x 120.65D	2
AAA31.250-023.812AA	31.25W x 47.50D	79.37W x 120.65D	2
AAA34.250-023.812AA	34.25W x 47.50D	87.00W x 120.65D	2
AAA37.250-023.812AA	37.25W x 47.50D	94.61W x 120.65D	2
AAA40.250-023.812AA	40.25W x 47.50D	102.23W x 120.65D	2
AAA43.250-023.812AA	43.25W x 47.50D	109.85W x 120.65D	2
AAA46.250-023.812AA	46.25W x 47.50D	117.48W x 120.65D	2
AAA28.250-029.750AA	28.25W x 59.50D	71.75W x 151.13D	2
AAA31.250-029.750AA	31.25W x 59.50D	79.37W x 151.13D	2
AAA34.250-029.750AA	34.25W x 59.50D	87.00W x 151.13D	2
AAA37.250-029.750AA	37.25W x 59.50D	94.61W x 151.13D	2
AAA40.250-029.750AA	40.25W x 59.50D	102.23W x 151.13D	2
AAA43.250-019.812AA	43.25W x 59.50D	109.85W x 151.13D	3
AAA46.250-019.812AA	46.25W x 59.50D	117.48W x 151.13D	3
AAA28.250-035.750AA	28.25W x 71.50D	71.75W x 181.61D	2
AAA31.250-035.750AA	31.25W x 71.50D	79.37W x 181.61D	2
AAA34.250-035.750AA	34.25W x 71.50D	87.00W x 181.61D	2
AAA37.250-023.812AA	37.25W x 71.50D	94.61W x 181.61D	3

P/N	FOR PENS		SECTIONS NEEDED
	Inches	Centimeters	
AAA40.250-023.812AA	40.25W x 71.50D	102.23W x 181.61D	3
AAA43.250-023.812AA	43.25W x 71.50D	109.85W x 181.61D	3
AAA46.250-023.812AA	46.25W x 71.50D	117.48W x 181.61D	3
AAA28.250-027.812AA	28.25W x 83.50D	71.75W x 212.09D	3
AAA31.250-027.812AA	31.25W x 83.50D	79.37W x 212.09D	3
AAA34.250-027.812AA	34.25W x 83.50D	87.00W x 212.09D	3
AAA37.250-027.812AA	37.25W x 83.50D	94.61W x 212.09D	3
AAA40.250-027.812AA	40.25W x 83.50D	102.23W x 212.09D	3
AAA43.250-020.875AA	43.25W x 83.50D	109.85W x 212.09D	4
AAA46.250-020.875AA	46.25W x 83.50D	117.48W x 212.09D	4
AAA28.250-031.812AA	28.25W x 95.50D	71.75W x 242.57D	3
AAA31.250-031.812AA	31.25W x 95.50D	79.37W x 242.57D	3
AAA34.250-031.812AA	34.25W x 95.50D	87.00W x 242.57D	3
AAA37.250-023.812AA	37.25W x 95.50D	94.61W x 242.57D	4
AAA40.250-023.812AA	40.25W x 95.50D	102.23W x 242.57D	4
AAA43.250-023.812AA	43.25W x 95.50D	109.85W x 242.57D	4
AAA46.250-023.812AA	46.25W x 95.50D	117.48W x 242.57D	4

Bail Hook for Removing Elevated Floor Sections

Stainless steel bail hook makes it easier to lift floor sections for cleaning. Slides easily through holes in floor sections to hook and lift floor without bending, stooping or contaminating hands.

P/N	DESCRIPTION
12400-00-AAAAAA	Handle with Hook



Section 4

Floor-Support Brackets and Rings for Stainless Steel Raised-Floor Pen Systems

SRF



213419



560207



Wall Support Rings

Stainless steel Support Rings mount directly to masonry walls in Stainless Steel Raised-Floor Pen Systems that use the facility wall for one or both ends of the System. For greater strength, rings may be mounted in mortar when wall is constructed. Please call for more information before building your walls. Refer to chart for number of Rings needed to fit your Pen System.

P/N	DESCRIPTION
213419	Bolt-on Floor Support Rings
560207	Floor Support Rings for Mortar Joints in End Walls

Wall-Mounted Floor Support Brackets

Stainless steel Support Brackets mount directly to masonry end walls in Stainless Steel Raised-Floor Pen Systems that use the facility wall for one or both ends of the System. Please call for specific construction information before building your walls.

P/N	FOR PENS	
	Inches	Centimeters
Bolt-on Floor Brackets		
CTP047.500	47.50D	120.65D
CTP059.500	59.50D	151.13D
CTP071.500	71.50D	181.61D
CTP083.500	83.50D	212.09D
CTP095.500	95.50D	242.57D
Bolt-on Floor Brackets for End Walls		
<i>Required for end walls when Gates are mounted to face of masonry partition walls.</i>		
CTM047.500	47.50D	120.65D
CTM059.500	59.50D	151.13D
CTM071.500	71.50D	181.61D
CTM083.500	83.50D	212.09D
CTM095.500	95.50D	242.57D

SUPPORT RING REQUIREMENT CHART

FOR PENS		RINGS	FOR PENS		RINGS
In.	Cm.	Per Side	In.	Cm.	Per Side
For 47.50-in. (120.65cm) deep pens			For 83.50-in. (212.09cm) deep pens		
28.25W	71.75W	4	28.25W	71.75W	6
31.25W	79.37W	4	31.25W	79.37W	6
34.25W	87.00W	4	34.25W	87.00W	6
37.25W	94.61W	4	37.25W	94.61W	6
40.25W	102.23W	4	40.25W	102.23W	6
43.25W	109.85W	4	43.25W	109.85W	8
46.25W	117.48W	4	46.25W	117.48W	8
For 59.50-in. (151.13cm) deep pens			For 95.50-in. (242.57cm) deep pens		
28.25W	71.75W	4	28.25W	71.75W	6
31.25W	79.37W	4	31.25W	79.37W	6
34.25W	87.00W	4	34.25W	87.00W	6
37.25W	94.61W	4	37.25W	94.61W	8
40.25W	102.23W	4	40.25W	102.23W	8
43.25W	109.85W	6	43.25W	109.85W	8
46.25W	117.48W	6	46.25W	117.48W	8
For 71.50-in. (181.61cm) deep pens					
28.25W	71.75W	4			
31.25W	79.37W	4			
34.25W	87.00W	4			
37.25W	94.61W	6			
40.25W	102.23W	6			
43.25W	109.85W	6			
46.25W	117.48W	6			

Section 4

End/Partition Panels for Masonry Pen Systems

MFF
MRF

END/PARTITION PANELS FOR MASONRY PENS

High-quality stainless steel panels attach securely to the top of masonry lower walls to create a safe, dependable system in minimal time. Our panels are constructed with Type 304 stainless steel tubular outer frame and a fully welded stainless steel grill, both with a uniform, non-glare finish.

Standard Upper Partition Panels measure 28.75-in. (73.03cm) high to work with our standard Gates when masonry partition walls measure 4-ft. (1.22m) high. Actual height of your pen partitions will depend on the height of your masonry walls.

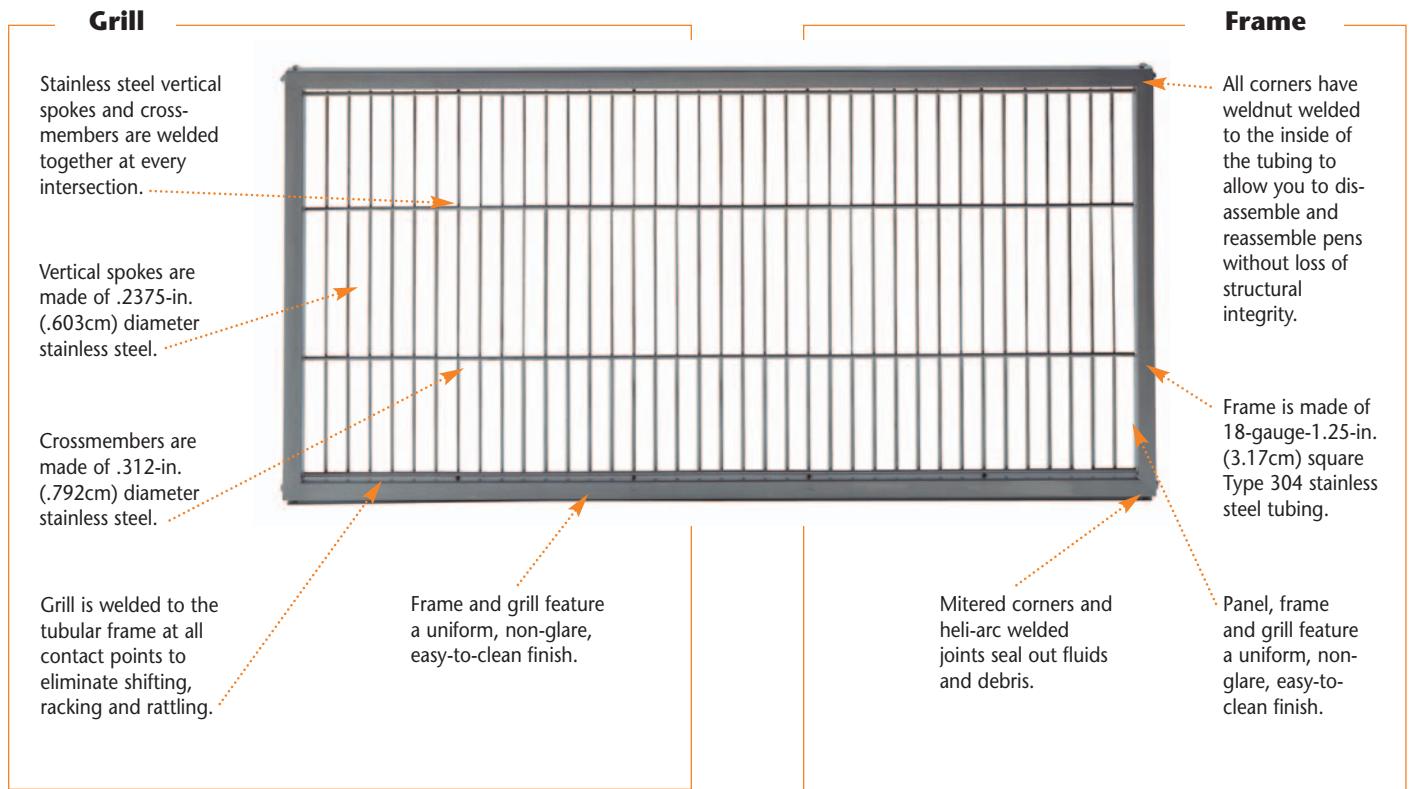

Upper End/Partition Panels

Order one End/Partition Panel for each partition between pens, and one for each end of your Pen System if you are not using your facility's walls.

P/N	DEPTH	
	Inches	Centimeters
ABAA0Z1A287504750AAA	47.50D	120.65D
ABAA0Z1A287505950AAA	59.50D	151.13D
ABAA0Z1A287507150AAA	71.50D	181.61D
ABAA0Z1A287508350AAA	83.50D	212.09D
ABAA0Z1A287509550AAA	95.50D	242.57D

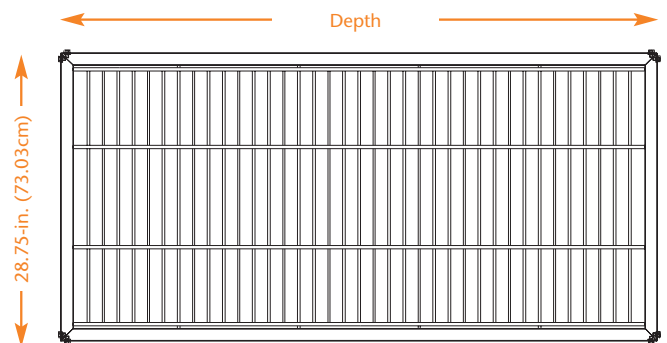

Coated Floors for Masonry Raised-Floor Pen Systems

MFF
MRF

Coated Floor Sections

Super strong expanded metal Floor Sections have a plastisol coating for warmth and comfort, as well as for easy cleaning. Waste fluids fall through the grate to the facility floor to be hosed away. Bright color makes debris more visible to encourage your kennel staff to keep pens more sanitary while animals are in your care.

Sections lift for a thorough cleaning with Hook sold separately below. Refer to chart below for the number of Floor Sections required to fit your Pens.

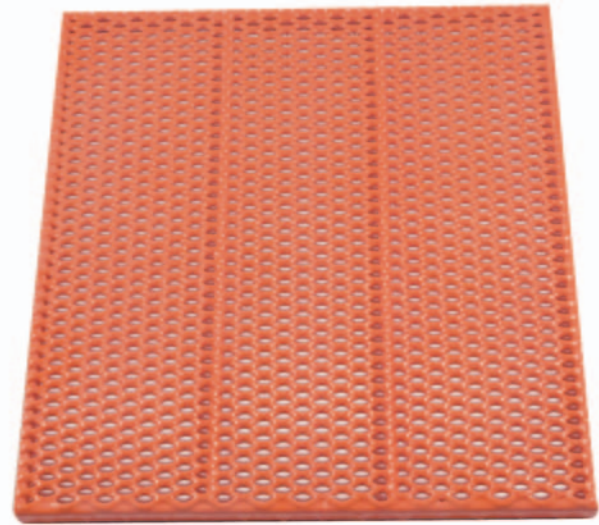

P/N	FOR PENS		SECTIONS NEEDED
	Inches	Centimeters	
EAA25.875-023.812AA	28.25W x 47.50D	71.75W x 120.65D	2
EAA28.875-023.812AA	31.25W x 47.50D	79.37W x 120.65D	2
EAA31.875-023.812AA	34.25W x 47.50D	87.00W x 120.65D	2
EAA34.875-023.812AA	37.25W x 47.50D	94.61W x 120.65D	2
EAA37.875-023.812AA	40.25W x 47.50D	102.23W x 120.65D	2
EAA40.875-023.812AA	43.25W x 47.50D	109.85W x 120.65D	2
EAA43.875-023.812AA	46.25W x 47.50D	117.48W x 120.65D	2
EAA25.875-029.750AA	28.25W x 59.50D	71.75W x 151.13D	2
EAA28.875-029.750AA	31.25W x 59.50D	79.37W x 151.13D	2
EAA31.875-029.750AA	34.25W x 59.50D	87.00W x 151.13D	2
EAA34.875-029.750AA	37.25W x 59.50D	94.61W x 151.13D	2
EAA37.875-029.750AA	40.25W x 59.50D	102.23W x 151.13D	2
EAA40.875-019.812AA	43.25W x 59.50D	109.85W x 151.13D	3
EAA43.875-019.812AA	46.25W x 59.50D	117.48W x 151.13D	3
EAA25.875-035.750AA	28.25W x 71.50D	71.75W x 181.61D	2
EAA28.875-035.750AA	31.25W x 71.50D	79.37W x 181.61D	2
EAA31.875-035.750AA	34.25W x 71.50D	87.00W x 181.61D	2
EAA34.875-023.812AA	37.25W x 71.50D	94.61W x 181.61D	3

P/N	FOR PENS		SECTIONS NEEDED
	Inches	Centimeters	
EAA37.875-023.812AA	40.25W x 71.50D	102.23W x 181.61D	3
EAA40.875-023.812AA	43.25W x 71.50D	109.85W x 181.61D	3
EAA43.875-023.812AA	46.25W x 71.50D	117.48W x 181.61D	3
EAA25.875-027.812AA	28.25W x 83.50D	71.75W x 212.09D	3
EAA28.875-027.812AA	31.25W x 83.50D	79.37W x 212.09D	3
EAA31.875-027.812AA	34.25W x 83.50D	87.00W x 212.09D	3
EAA34.875-027.812AA	37.25W x 83.50D	94.61W x 212.09D	3
EAA37.875-027.812AA	40.25W x 83.50D	102.23W x 212.09D	3
EAA40.875-020.875AA	43.25W x 83.50D	109.85W x 212.09D	4
EAA43.875-020.875AA	46.25W x 83.50D	117.48W x 212.09D	4
EAA25.875-031.812AA	28.25W x 95.50D	71.75W x 242.57D	3
EAA28.875-031.812AA	31.25W x 95.50D	79.37W x 242.57D	3
EAA31.875-031.812AA	34.25W x 95.50D	87.00W x 242.57D	3
EAA34.875-023.812AA	37.25W x 95.50D	94.61W x 242.57D	4
EAA37.875-023.812AA	40.25W x 95.50D	102.23W x 242.57D	4
EAA40.875-023.812AA	43.25W x 95.50D	109.85W x 242.57D	4
EAA43.875-023.812AA	46.25W x 95.50D	117.48W x 242.57D	4

Bail Hook for Removing Elevated Floor Sections

Stainless steel bail hook makes it easier to lift floor sections for cleaning. Slides easily through holes in floor sections to hook and lift floor without bending, stooping or contaminating hands.

P/N	DESCRIPTION
12400-00-AAAAAA	Handle with Hook



Floor-Support Brackets and Rings for Masonry Raised-Floor Pen Systems

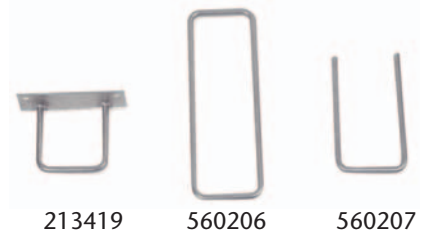

MFF
MRF

Wall Support Rings

Stainless steel Support Rings mount directly to masonry walls in Masonry Raised-Floor Pen Systems. For greater strength, rings may be mounted in mortar when wall is constructed. Please call for more information before building your walls. Refer to chart for number of Rings needed to fit your Pen System.

P/N	DESCRIPTION
213419	Bolt-on Floor Support Rings
560207	Floor Support Rings for Mortar Joints in End Walls
560206	Floor Support Rings for Mortar Joints in Masonry Partition Walls

Wall-Mounted Floor Support Brackets

Stainless steel Support Brackets mount directly to masonry walls in Masonry Raised-Floor Pen Systems. Please call for specific construction information before building your walls.

P/N	FOR PENS	
	Inches	Centimeters
Bolt-on Floor Brackets		
CTP047.500	47.50D	120.65D
CTP059.500	59.50D	151.13D
CTP071.500	71.50D	181.61D
CTP083.500	83.50D	212.09D
CTP095.500	95.50D	242.57D
Bolt-on Floor Brackets for End Walls		
<i>Required for end walls when Gates are mounted to face of masonry partition walls.</i>		
CTM047.500	47.50D	120.65D
CTM059.500	59.50D	151.13D
CTM071.500	71.50D	181.61D
CTM083.500	83.50D	212.09D
CTM095.500	95.50D	242.57D

SUPPORT RING REQUIREMENT CHART

FOR PENS			RINGS	FOR PENS			RINGS
In.	Cm.	Per Side		In.	Cm.	Per Side	
For 47.50-in. (120.65cm) deep pens				For 83.50-in. (212.09cm) deep pens			
28.25W	71.75W	4		28.25W	71.75W	6	
31.25W	79.37W	4		31.25W	79.37W	6	
34.25W	87.00W	4		34.25W	87.00W	6	
37.25W	94.61W	4		37.25W	94.61W	6	
40.25W	102.23W	4		40.25W	102.23W	6	
43.25W	109.85W	4		43.25W	109.85W	8	
46.25W	117.48W	4		46.25W	117.48W	8	
For 59.50-in. (151.13cm) deep pens				For 95.50-in. (242.57cm) deep pens			
28.25W	71.75W	4		28.25W	71.75W	6	
31.25W	79.37W	4		31.25W	79.37W	6	
34.25W	87.00W	4		34.25W	87.00W	6	
37.25W	94.61W	4		37.25W	94.61W	8	
40.25W	102.23W	4		40.25W	102.23W	8	
43.25W	109.85W	6		43.25W	109.85W	8	
46.25W	117.48W	6		46.25W	117.48W	8	
For 71.50-in. (181.61cm) deep pens							
28.25W	71.75W	4					
31.25W	79.37W	4					
34.25W	87.00W	4					
37.25W	94.61W	6					
40.25W	102.23W	6					
43.25W	109.85W	6					
46.25W	117.48W	6					

Back Panels for Stainless Steel Pen Systems

SFF
SRF

BACK PANELS FOR STAINLESS STEEL PENS

Stainless steel Back Panels complete your modular Pen System when installing a free-standing system or back-to-

back pens. These panels are not necessary if the back of your Pen System is your facility wall.

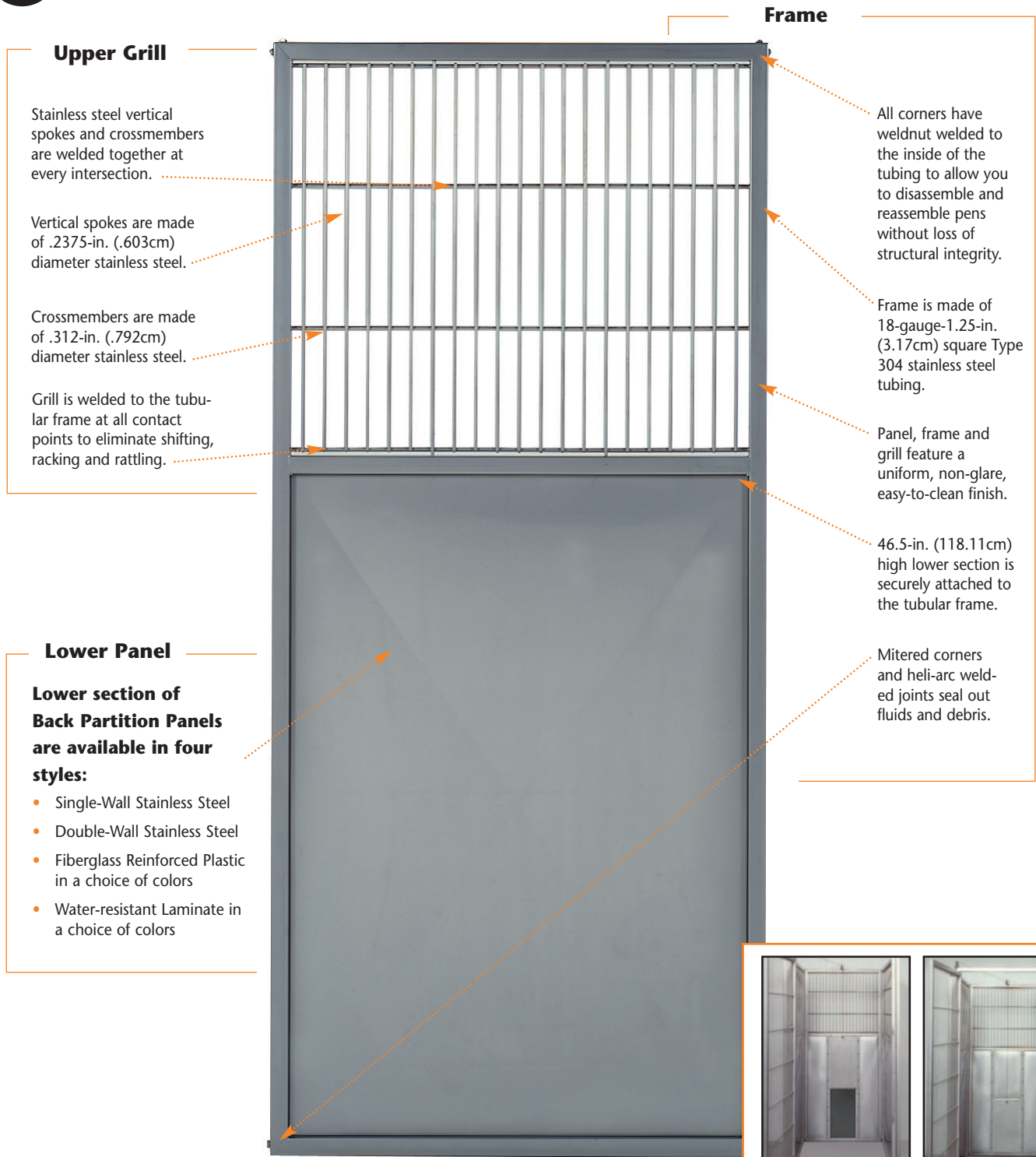

Upper Grill

Stainless steel vertical spokes and crossmembers are welded together at every intersection.

Vertical spokes are made of .2375-in. (.603cm) diameter stainless steel.

Crossmembers are made of .312-in. (.792cm) diameter stainless steel.

Grill is welded to the tubular frame at all contact points to eliminate shifting, racking and rattling.

Lower Panel

Lower section of Back Partition Panels are available in four styles:

- Single-Wall Stainless Steel
- Double-Wall Stainless Steel
- Fiberglass Reinforced Plastic in a choice of colors
- Water-resistant Laminate in a choice of colors

Frame

All corners have weldnut welded to the inside of the tubing to allow you to disassemble and reassemble pens without loss of structural integrity.

Frame is made of 18-gauge-1.25-in. (3.17cm) square Type 304 stainless steel tubing.

Panel, frame and grill feature a uniform, non-glare, easy-to-clean finish.

46.5-in. (118.11cm) high lower section is securely attached to the tubular frame.

Mitered corners and heli-arc welded joints seal out fluids and debris.

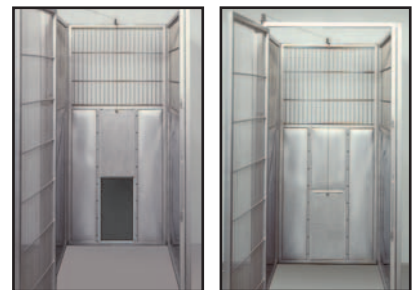

Back Panels with Guillotine doors add to the versatility of your Pen System.

Back Panels for Stainless Steel Pen Systems

SFF
SRF

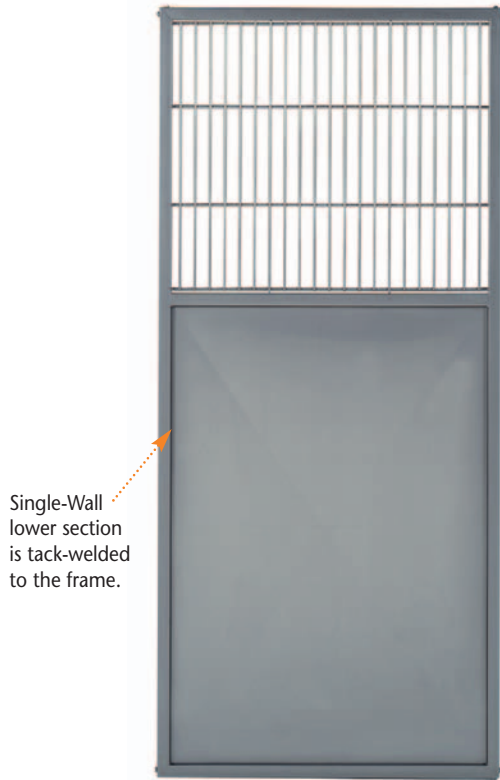

Single-Wall lower section is tack-welded to the frame.

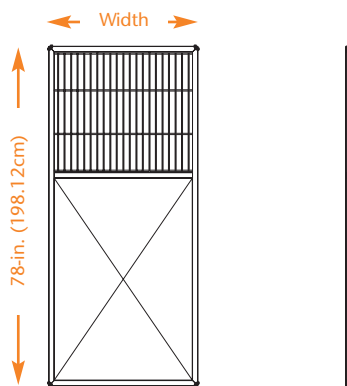

Stainless Steel Single-Wall Back Panels

The most sanitary, longest lasting partition panel we sell. Single-ply, 46.5-in. (118.11cm) high stainless steel lower panel is tack welded to the tubular stainless steel frame. Upper stainless steel grill allows you to see through Partitions into the next pen. Panels measure 78-in. (198.12cm) high overall.

P/N	WIDTH	
	Inches	Centimeters
ABAI1A1E780002825AAA	28.25W	71.75W
ABAI1A1E780003125AAA	31.25W	79.37W
ABAI1A1E780003425AAA	34.25W	87.00W
ABAI1A1E780003725AAA	37.25W	94.61W
ABAI1A1E780004025AAA	40.25W	102.23W
ABAI1A1E780004325AAA	43.25W	109.85W
ABAI1A1E780004625AAA	46.25W	117.48W



Double-Wall lower section is tack-welded to the frame.

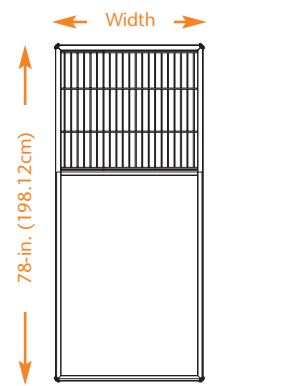

Stainless Steel Double-Wall Back Panels

Sound-deadening insulation is sandwiched between two 46.5-in. (118.11cm) high stainless steel panels. Panels are tack welded to the tubular stainless steel frame. Upper stainless steel grill allows you to see through Partitions into the next pen. Panels measure 78-in. (198.12cm) high overall.

P/N	WIDTH	
	Inches	Centimeters
SBAI1A1E780002825AAA	28.25W	71.75W
SBAI1A1E780003125AAA	31.25W	79.37W
SBAI1A1E780003425AAA	34.25W	87.00W
SBAI1A1E780003725AAA	37.25W	94.61W
SBAI1A1E780004025AAA	40.25W	102.23W
SBAI1A1E780004325AAA	43.25W	109.85W
SBAI1A1E780004625AAA	46.25W	117.48W

Back Panels for Stainless Steel Pen Systems

SFF
SRF



SSCI Fiberglass Reinforced Plastic Panels; see Section A, page 2 for color selection.

Lower section is secured to frame with stainless steel continuous die-formed brackets, machine screws and locknuts.



SSCI laminated items are available in SSCI standard colors, SSCI optional colors, or a spectrum of Customer-selected colors.

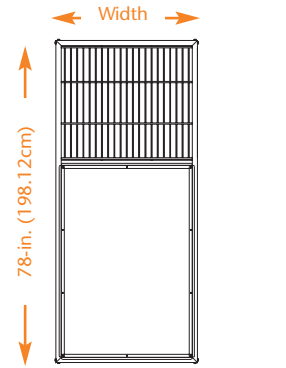
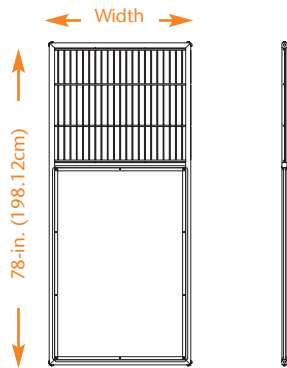

Fiberglass Reinforced Plastic Back Panels

Lower corrugated-style panel is made of pebble-finish plastic reinforced with fiberglass for exceptional durability. Available in a choice of colors to brighten up your kennel. Upper stainless steel grill allows you to see through Partitions into the next pen. Panels measure 78-in. (198.12cm) high overall.

Laminated Back Panels

Lower 46.5-in. (118.11cm) high panel features high-pressure plastic laminate over water-resistant materials in a choice of colors to match your facility décor. Upper stainless steel grill allows you to see through Partitions into the next pen. Panels are not guaranteed against delaminating, yet may be replaced to remain fresh and up to date. Panels measure 78-in. (198.12cm) high overall.

P/N	WIDTH	
	Inches	Centimeters
ABAI1A1Q78002825 ___ †	28.25W	71.75W
ABAI1A1Q78003125 ___ †	31.25W	79.37W
ABAI1A1Q78003425 ___ †	34.25W	87.00W
ABAI1A1Q78003725 ___ †	37.25W	94.61W
ABAI1A1Q78004025 ___ †	40.25W	102.23W
ABAI1A1Q78004325 ___ †	43.25W	109.85W
ABAI1A1Q78004625 ___ †	46.25W	117.48W

P/N	WIDTH	
	Inches	Centimeters
ABAI1A1L78002825 ___ †	28.25W	71.75W
ABAI1A1L78003125 ___ †	31.25W	79.37W
ABAI1A1L78003425 ___ †	34.25W	87.00W
ABAI1A1L78003725 ___ †	37.25W	94.61W
ABAI1A1L78004025 ___ †	40.25W	102.23W
ABAI1A1L78004325 ___ †	43.25W	109.85W
ABAI1A1L78004625 ___ †	46.25W	117.48W

Important: These customer order requirements, in addition to other customer order requirements, must be satisfied prior to the beginning of manufacturing lead time: †Specify 4-digit Color code. See Color Selections, Section A, pages 1 & 2 for Color Codes.

Section
4

Back Panels for Stainless Steel Pen Systems

SFF
SRF

GUILLOTINE DOOR BACK PANELS FOR STAINLESS STEEL PENS

Unique pulley design allows you to easily open the guillotine door from the front of the cage. Handle bracket holds door securely in place for safety. Includes cable and cable guide hardware.

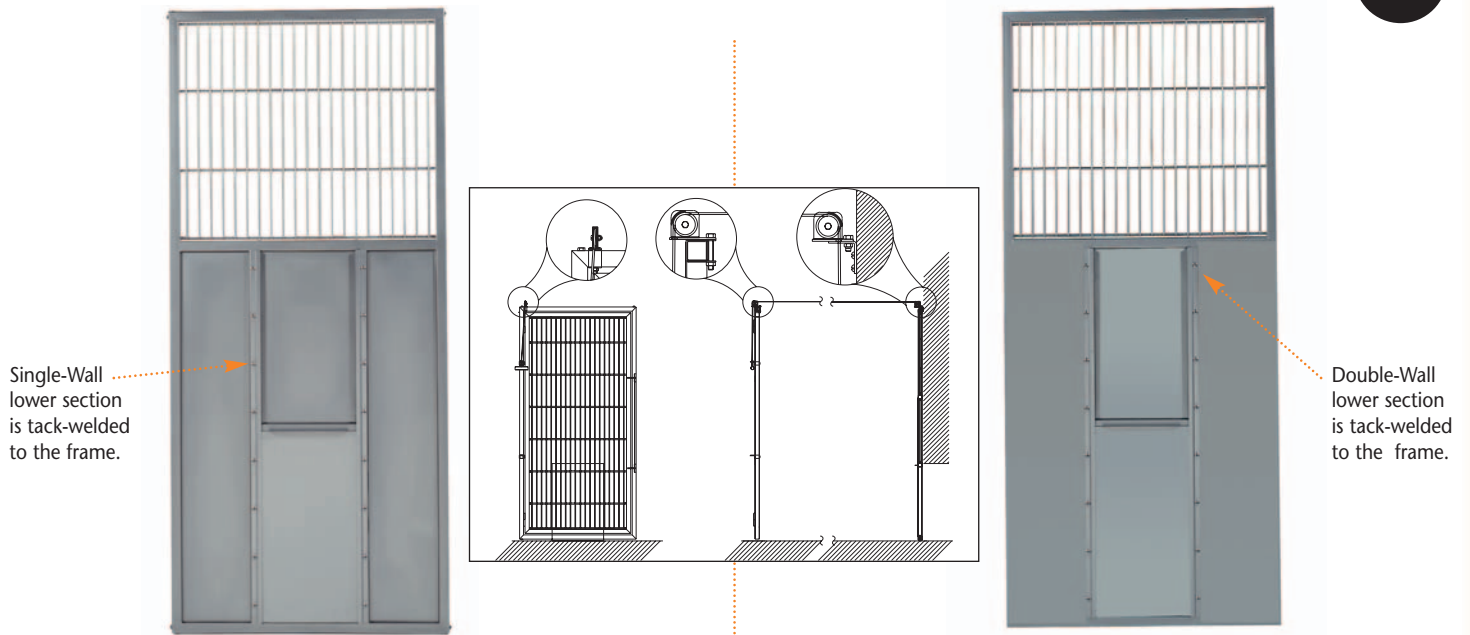

Single-Wall lower section is tack-welded to the frame.

Double-Wall lower section is tack-welded to the frame.

Stainless Steel Single-Wall Back Panels with Guillotine Door

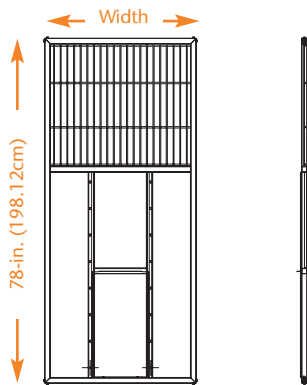

The most sanitary, longest lasting partition panel we sell. Single-ply, 46.5-in. (118.11cm) high stainless steel lower panel is tack welded to the tubular stainless steel frame. Features stainless steel guillotine door assembly with 13.626-in.W x 24.750-in.H (34.61cmW x 62.87cmH) door opening. Upper stainless steel grill allows you to see through Partitions into the next pen. Panels measure 78-in. (198.12cm) high overall.

Stainless Steel Double-Wall Back Panels with Guillotine Door

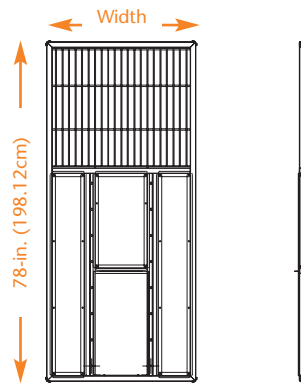

Sound-deadening insulation is sandwiched between two 46.5-in. (118.11cm) high stainless steel panels. Panels are tack welded to the tubular stainless steel frame. Features stainless steel guillotine door assembly with 13.626-in.W x 24.750-in.H (34.61cmW x 62.87cmH) door opening. Upper stainless steel grill allows you to see through Partitions into the next pen. Panels measure 78-in. (198.12cm) high overall.

P/N	WIDTH	
	Inches	Centimeters
ABC11A1E780002825AAA	28.25W	71.75W
ABC11A1E780003125AAA	31.25W	79.37W
ABC11A1E780003425AAA	34.25W	87.00W
ABC11A1E780003725AAA	37.25W	94.61W
ABC11A1E780004025AAA	40.25W	102.23W
ABC11A1E780004325AAA	43.25W	109.85W
ABC11A1E780004625AAA	46.25W	117.48W

P/N	WIDTH	
	Inches	Centimeters
SBC11A1E780002825AAA	28.25W	71.75W
SBC11A1E780003125AAA	31.25W	79.37W
SBC11A1E780003425AAA	34.25W	87.00W
SBC11A1E780003725AAA	37.25W	94.61W
SBC11A1E780004025AAA	40.25W	102.23W
SBC11A1E780004325AAA	43.25W	109.85W
SBC11A1E780004625AAA	46.25W	117.48W

Back Panels for Stainless Steel Pen Systems

SFF
SRF



SSCI Fiberglass Reinforced Plastic Panels; see Section A, page 2 for color selection.



SSCI laminated items are available in SSCI standard colors, SSCI optional colors, or a spectrum of customer-selected colors.

Lower section is secured to frame with stainless steel continuous die-formed brackets, machine screws and locknuts.

Fiberglass Reinforced Plastic Back Panels with Guillotine Door

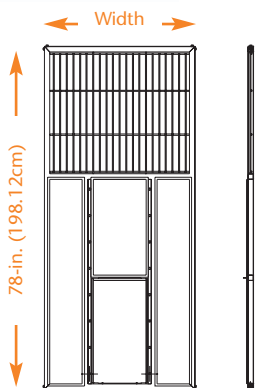

Laminated Back Panels with Guillotine Door

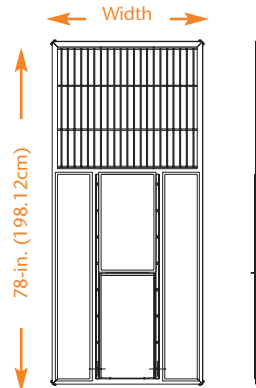

Lower corrugated-style panel is made of pebble-finish plastic reinforced with fiberglass for exceptional durability. Available in a choice of colors to brighten up your kennel. Features stainless steel guillotine door assembly with 13.626-in.W x 24.750-in.H (34.61cmW x 62.87cmH) door opening. Upper stainless steel grill allows you to see through Partitions into the next pen. Panels measure 78-in. (198.12cm) high overall.

Lower 46.5-in. (118.11cm) high panel features high-pressure plastic laminate over water-resistant materials in a choice of colors to match your facility décor. Features stainless steel guillotine door assembly with 13.626-in.W x 24.750-in.H (34.61cmW x 62.87cmH) door opening. Upper stainless steel grill allows you to see into pen. Panels are not guaranteed against delaminating, yet may be replaced to remain fresh and up to date. Panels measure 78-in. (198.12cm) high overall.

P/N	WIDTH	
	Inches	Centimeters
ABC11A1Q78002825 ___ †	28.25W	71.75W
ABC11A1Q78003125 ___ †	31.25W	79.37W
ABC11A1Q78003425 ___ †	34.25W	87.00W
ABC11A1Q78003725 ___ †	37.25W	94.61W
ABC11A1Q78004025 ___ †	40.25W	102.23W
ABC11A1Q78004325 ___ †	43.25W	109.85W
ABC11A1Q78004625 ___ †	46.25W	117.48W

P/N	WIDTH	
	Inches	Centimeters
ABC11A1L78002825 ___ †	28.25W	71.75W
ABC11A1L78003125 ___ †	31.25W	79.37W
ABC11A1L78003425 ___ †	34.25W	87.00W
ABC11A1L78003725 ___ †	37.25W	94.61W
ABC11A1L78004025 ___ †	40.25W	102.23W
ABC11A1L78004325 ___ †	43.25W	109.85W
ABC11A1L78004625 ___ †	46.25W	117.48W

Important: These customer order requirements, in addition to other customer order requirements, must be satisfied prior to the beginning of manufacturing lead time: † Specify 4-digit Color code. See Color Selections, Section A, pages 1 & 2 for Color Codes.

SFF

Fold-up Trough Cover

Stainless steel panel covers the floor drain trough with just enough clearance to allow liquids and debris to be hosed under it to the drain. Helps animals stay cleaner and drier by preventing access to the trough. Folds up easily for complete pen and trough cleaning.

Shelf attaches securely to pen partitions or to one partition and the wall. Mounting bracket is required if attaching to a facility wall.



P/N	FOR PENS	
	Inches	Centimeters
DGE28.000-012.000AA	28.25W	71.75W
DGE31.000-012.000AA	31.25W	79.37W
DGE34.000-012.000AA	34.25W	87.00W
DGE37.000-012.000AA	37.25W	94.61W
DGE40.000-012.000AA	40.25W	102.23W
DGE43.000-012.000AA	43.25W	109.85W
DGE46.000-012.000AA	46.25W	117.48W

Mounting Bracket

620300

Mounting Bracket for Facility Walls

Fold-up Resting Shelf

Raised platform provides an additional surface for animals to rest on above the floor. Comfortable polyethylene shelf is attached to a 18-gauge-1.00-in. (2.54cm) square Type 304 stainless steel tubular frame. Slight space between frame and center allows fluids to flow through to keep animals drier. Shelf attaches securely to pen partitions or to one partition and the wall with Pivoting Mounting Bracket. Folds up out of the way when cleaning the pen. Optional Shelf Latch, sold below, holds shelf in folded up position. Order Mounting Brackets to fit your Pen System including left and/or right mounting brackets for end walls if using facility walls.

P/N	FOR PENS	
	Inches	Centimeters
DGC26.688-018.000AA	28.25W	71.75W
DGC29.688-018.000AA	31.25W	79.37W
DGC32.688-018.000AA	34.25W	87.00W
DGC35.688-018.000AA	37.25W	94.61W
DGC38.688-018.000AA	40.25W	102.23W
DGC41.688-018.000AA	43.25W	109.85W
DGC44.688-018.000AA	46.25W	117.48W

Mounting Hardware

P/N	DESCRIPTION
Pivoting Mounting Bracket	
ACUC040.000	Left Bracket for Stainless Steel Panel
ACUC041.000	Right Bracket for Stainless Steel Panel
ACUC039.000	Partition Bracket for Stainless Steel Panel
614164	Left Bracket for Facility Wall
614165	Right Bracket for Facility Wall
Shelf Latch	
212581	Latch for Stainless Steel Panels or Facility Walls



SFF
SRF



S
e
c
t
i
o
n
4

For Product Information Call TOLL-FREE 1-800-323-7366 • (847) 537-9320 • Fax (847) 537-9061

Hours: 8:30am - 5:00pm CST Monday - Friday

Visit our website at: www.suburbansurgical.com

Back Panels for Masonry Pen Systems

MFF
MRF

BACK PANELS FOR MASONRY PENS

High-quality stainless steel panels attach securely to the top of masonry lower walls to create a safe, dependable system in minimal time. Our panels are constructed with an outer frame made of Type 304 tubular stainless steel and a fully welded stainless steel grill, both with a uniform, non-glare

finish. Standard Upper Panels measure 28.75-in. (73.03cm) high to work with our standard Gates when masonry back walls measure 4-ft. (1.22m) high. Actual height of your pen backs will depend on the height of your masonry walls.

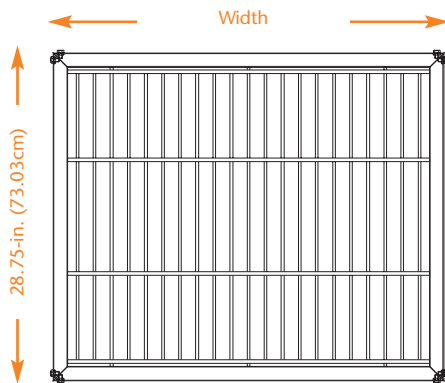
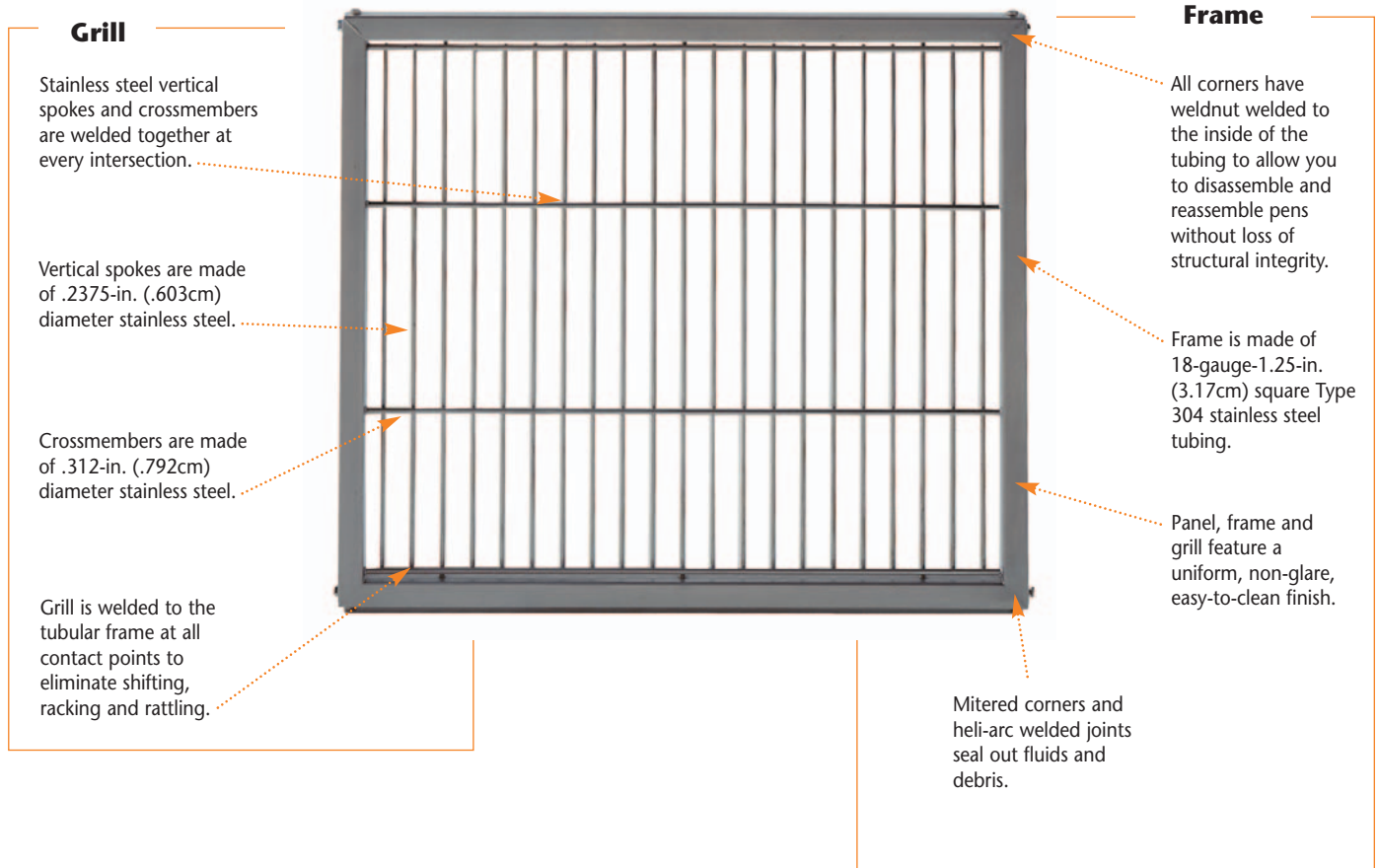

Upper Back Panel

Order one Back Panel for each individual pen if you are not using your facility's walls.

P/N	WIDTH	
	Inches	Centimeters
ABAA0Z1A287502825AAA	28.25W	71.75W
ABAA0Z1A287503125AAA	31.25W	79.37W
ABAA0Z1A287503425AAA	34.25W	87.00W
ABAA0Z1A287503725AAA	37.25W	94.61W
ABAA0Z1A287504025AAA	40.25W	102.23W
ABAA0Z1A287504325AAA	43.25W	109.85W
ABAA0Z1A287504625AAA	46.25W	117.48W

Guillotine Door Kits for Masonry Pen Systems

MFF
MRF



Guillotine Door Kits for Pens with lower masonry walls

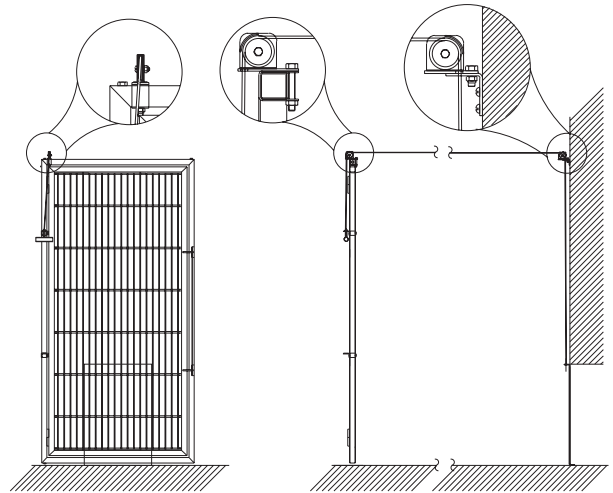

Guillotine Door Kits for Masonry Facility Floor or Raised-Floor Pens

Add a Guillotine Door to the back wall of your Masonry Pen System to give animals access to an outside pen or to another inside pen while you clean. Unique pulley design allows you to easily open the Guillotine Door from the front of the pen. Handle bracket holds door securely in place for safety. Includes cable and cable guide hardware. Select the door you need for the largest animal you may board.

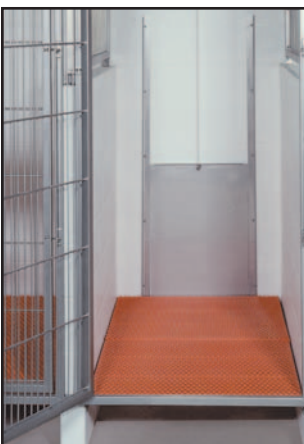

Guillotine Door Kits for Pens with full-height masonry walls

P/N	GUILLOTINE DOOR OPENING	
	Inches	Centimeters
12405-00-BVCLAA	12W x 16H	30.48W x 40.64H
12405-00-CDCTAA	14W x 18H	35.56W x 45.72H
12405-00-CLDRAA	16W x 24H	40.64W x 60.96H
12405-00-CTEHAA	18W x 28H	45.72W x 71.12H

Guillotine Door Kits are available for any size pen you desire. Please call for more information.

Accessories for Masonry Pen Systems

MFF

Fold-up Trough Cover

Stainless steel panel covers the floor drain trough with just enough clearance to allow liquids and debris to be hosed under it to the drain. Helps animals stay cleaner and drier by preventing access to the trough. Folds up easily for complete pen and trough cleaning. Shelf attaches securely to the wall with Mounting Bracket sold below.

P/N	FOR PENS	
	Inches	Centimeters
DGE28.000-012.000AA	28.25W	71.75W
DGE31.000-012.000AA	31.25W	79.37W
DGE34.000-012.000AA	34.25W	87.00W
DGE37.000-012.000AA	37.25W	94.61W
DGE40.000-012.000AA	40.25W	102.23W
DGE43.000-012.000AA	43.25W	109.85W
DGE46.000-012.000AA	46.25W	117.48W
Mounting Bracket 620300	Mounting Bracket for Facility Walls	



MFF
MRF



Fold-up Resting Shelf

Raised platform provides an additional surface for animals to rest on above the floor. Comfortable polyethylene shelf is attached to a 18-gauge-1.00-in. (2.54cm) square Type 304 stainless steel tubular frame. Slight space between frame and center allows fluids to flow through to keep animals drier. Shelf attaches securely to the wall with Pivoting Mounting Bracket. Folds up out of the way when cleaning the pen. Optional Shelf Latch, sold below, holds shelf in folded up position for cleaning. Order Mounting Brackets to fit your Pen System.

P/N	FOR PENS	
	Inches	Centimeters
DGC26.688-018.000AA	28.25W	71.75W
DGC29.688-018.000AA	31.25W	79.37W
DGC32.688-018.000AA	34.25W	87.00W
DGC35.688-018.000AA	37.25W	94.61W
DGC38.688-018.000AA	40.25W	102.23W
DGC41.688-018.000AA	43.25W	109.85W
DGC44.688-018.000AA	46.25W	117.48W

Mounting Hardware

P/N	DESCRIPTION
Pivoting Mounting Bracket	
614164	Left Bracket for Masonry Wall
614165	Right Bracket for Masonry Wall
Shelf Latch	
212581	Latch for Masonry Walls

SFF
SRF
MFF
MRF



Top Panel Grills

Stainless steel Top Panels allow you create fully enclosed pens to house cats and other climbing animals in your Total Animal Pen System. Features a 16-gauge Type 304 stainless steel die-formed angle frame with a fully welded, full-length grill. Spokes are spaced 1.5-in. (3.81cm) and welded to .312-in. (.79cm) diameter crossmembers at all contact points. Crossmembers are fully circumference heli-arc welded to the frame for stability. Frame and grill feature our uniform, non-glare finish.

P/N	FOR PENS	
	Inches	Centimeters
DMA28.250-047.500AAA	28.25W x 47.50D	71.75W x 120.65D
DMA31.250-047.500AAA	31.25W x 47.50D	79.37W x 120.65D
DMA34.250-047.500AAA	34.25W x 47.50D	87.00W x 120.65D
DMA37.250-047.500AAA	37.25W x 47.50D	94.61W x 120.65D
DMA40.250-047.500AAA	40.25W x 47.50D	102.23W x 120.65D
DMA43.250-047.500AAA	43.25W x 47.50D	109.85W x 120.65D
DMA46.250-047.500AAA	46.25W x 47.50D	117.48W x 120.65D
DMA28.250-059.500AAA	28.25W x 59.50D	71.75W x 151.13D
DMA31.250-059.500AAA	31.25W x 59.50D	79.37W x 151.13D
DMA34.250-059.500AAA	34.25W x 59.50D	87.00W x 151.13D
DMA37.250-059.500AAA	37.25W x 59.50D	94.61W x 151.13D
DMA40.250-059.500AAA	40.25W x 59.50D	102.23W x 151.13D
DMA43.250-059.500AAA	43.25W x 59.50D	109.85W x 151.13D
DMA46.250-059.500AAA	46.25W x 59.50D	117.48W x 151.13D
DMA28.250-071.500AAA	28.25W x 71.50D	71.75W x 181.61D
DMA31.250-071.500AAA	31.25W x 71.50D	79.37W x 181.61D
DMA34.250-071.500AAA	34.25W x 71.50D	87.00W x 181.61D
DMA37.250-071.500AAA	37.25W x 71.50D	94.61W x 181.61D

P/N	FOR PENS	
	Inches	Centimeters
DMA40.250-071.500AAA	40.25W x 71.50D	102.23W x 181.61D
DMA43.250-071.500AAA	43.25W x 71.50D	109.85W x 181.61D
DMA46.250-071.500AAA	46.25W x 71.50D	117.48W x 181.61D
DMA28.250-083.500AAA	28.25W x 83.50D	71.75W x 212.09D
DMA31.250-083.500AAA	31.25W x 83.50D	79.37W x 212.09D
DMA34.250-083.500AAA	34.25W x 83.50D	87.00W x 212.09D
DMA37.250-083.500AAA	37.25W x 83.50D	94.61W x 212.09D
DMA40.250-083.500AAA	40.25W x 83.50D	102.23W x 212.09D
DMA43.250-083.500AAA	43.25W x 83.50D	109.85W x 212.09D
DMA46.250-083.500AAA	46.25W x 83.50D	117.48W x 212.09D
DMA28.250-095.500AAA	28.25W x 95.50D	71.75W x 242.57D
DMA31.250-095.500AAA	31.25W x 95.50D	79.37W x 242.57D
DMA34.250-095.500AAA	34.25W x 95.50D	87.00W x 242.57D
DMA37.250-095.500AAA	37.25W x 95.50D	94.61W x 242.57D
DMA40.250-095.500AAA	40.25W x 95.50D	102.23W x 242.57D
DMA43.250-095.500AAA	43.25W x 95.50D	109.85W x 242.57D
DMA46.250-095.500AAA	46.25W x 95.50D	117.48W x 242.57D

Back Spreader Bars

Use Spreader Bars to connect the back of End/Partition Panels to each other when no Back Panels are used and you do not want to attach the End/Partition Panels to the facility wall. Bars help keep your Pen System rigid and sturdy. Spreader bars are sold as each, order as many as you will need.

P/N	FOR PENS	
	Inches	Centimeters
ACTQ030.000	28.25W	71.75W
ACTQ033.000	31.25W	79.37W
ACTQ036.000	34.25W	87.00W
ACTQ039.000	37.25W	94.61W
ACTQ042.000	40.25W	102.23W
ACTQ045.000	43.25W	109.85W
ACTQ048.000	46.25W	117.48W

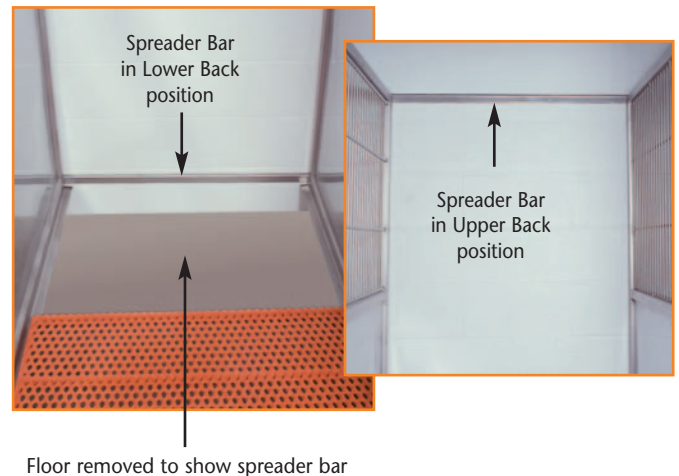

Section
4

Accessories for Total Pen Systems

SFF
SRF
MFF
MRF

Add these professional stainless steel accessories to your Total Animal Pen System to enhance the quality of your care.



Food and Water Bowls

Stainless steel bowls are easy to clean and sanitize to ensure animal comfort and safety.

P/N	CAPACITY	
	U.S. Liquid	Metric
12305-00-A2AAAA	1 Pint	0.47 Liters
12305-00-A4AAAA	1 Quart	0.95 Liters
12305-00-A6AAAA	2 Quarts	1.89 Liters
Bowl for Gates with built-in Bowl Holder		
12308-00-A5AAAA	1.5 Quarts	1.42 Liters

Food and Water Bowl Holders

Attach securely to cage door to hold stainless steel bowls sold above. Designed to keep bowl off the floor and eliminate spills. Made of electropolished stainless steel.

P/N	FITS BOWL SIZE	
	U.S. Liquid	Metric
12335-00-A2AAAA	1 Pint	0.47 Liters
12335-00-A4AAAA	1 Quart	0.95 Liters
12335-00-A6AAAA	2 Quarts	1.89 Liters

SFF
SRF
MFF
MRF



Card Holders

Use to display animal's name, weight, medication needs, release date, or other pertinent information. Attaches securely to the cage door to hold identification cards on three sides. Made of durable, easy to sanitize stainless steel. Cards slide into holder from top.

P/N	DIMENSIONS	
	Inches	Centimeters
12300-00-ATALAA	5W x 3H	12.70W x 7.62H
12300-00-AXAPAA	6W x 4H	15.24W x 10.16H
12300-00-BFATAA	8W x 5H	20.32W x 12.70H

Clipboards

Clips to the front of cage to hold information about the animal in your care. Yet lifts off quickly and easily to use as a writing surface to update the chart. Clip holds chart securely to keep all pertinent information at hand and easily accessible. Made of durable, easy to sanitize stainless steel.

P/N	DIMENSIONS	
	Inches	Centimeters
12302-00-BJAXAA	9W x 6H	22.86W x 15.24H
12302-00-BJBVAA	9W x 12H	22.86W x 30.48H



Clipboard with Bin

Bin/clipboard combination lets you keep medicines and dispensing schedule right on patient's cage. Helps to remind you when the next dose is due. Made of durable, easy to sanitize stainless steel.

P/N	BIN HEIGHT		OVERALL DIMENSIONS	
	In.	Cm	In.	Cm
12304-00-AXBAL	4.188H	10.64H	6W x 9H x 3D	15.24W x 22.86H x 7.62D
12304-00-BJBVAL	5.188H	13.18H	9W x 12H x 3D	22.86W x 30.48H x 7.62D

Total Animal Pen Systems

PUT OUR DESIGN TEAM TO WORK

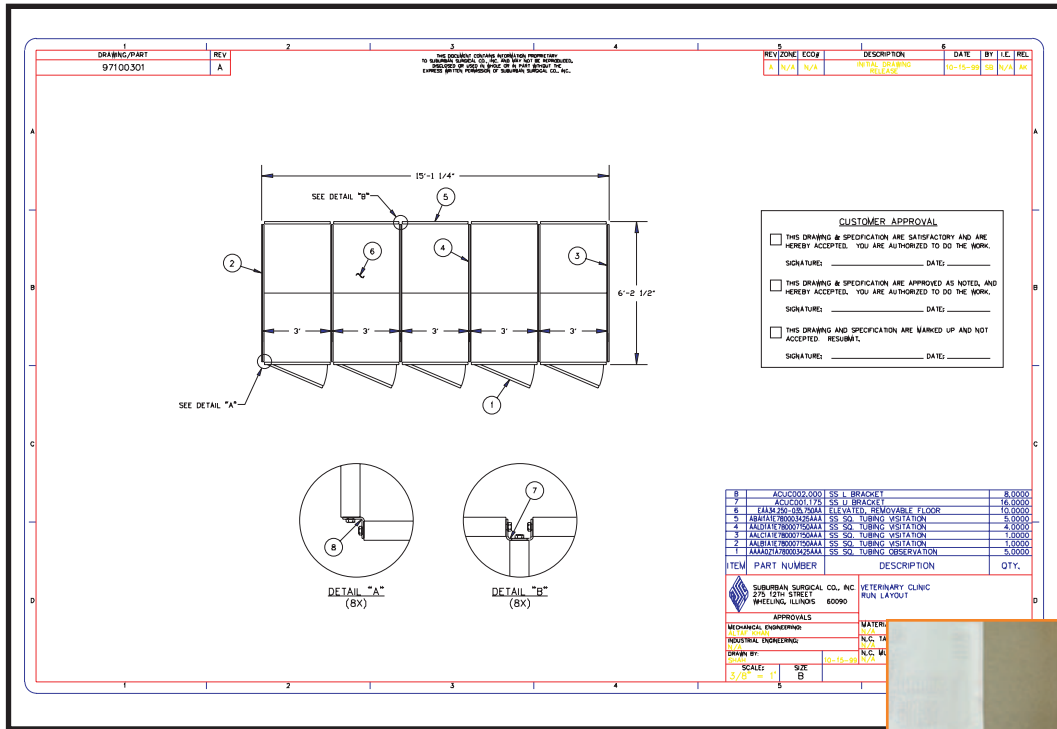

Detailed drawings of our Total Animal Pen System plans list all the necessary modular components. This visual representation helps ensure your Total Pen System will fit right and meet your specifications.

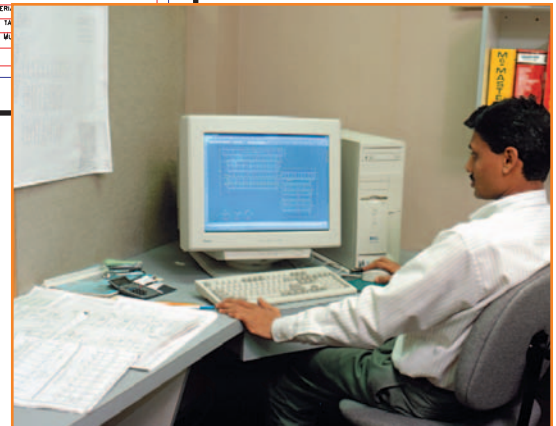

Our team of experienced designers will work with your measurements, specifications and budget to create the perfect Total Animal Pen System for your facility.

THE PERFECT TOTAL ANIMAL PEN SYSTEM IS JUST A PHONE CALL AWAY

We understand that many factors come into play when deciding on an animal pen system. The size of your facility, the number of pens you would like in the run, how much maintenance is required, and perhaps most important of all, your budget.

That's the beauty of a Total Animal Pen System from Suburban Surgical. Our completely modular components can be assembled to fit all your requirements. Whether you need a completely free-standing system, you prefer a raised-floor design, your system

can utilize your facility's back or end walls, or even desire a system with masonry partitions, we will work with you to help you create the right system for you.

Our Design Team can start with your architect's drawings, or a dimensional drawing with doors and windows indicated. We want your installation to maximize your available space, fit right, set-up smoothly and provide years of trouble-free service to add to your bottom line.

Please call your SSCI or local authorized representative today and put us to work for you.

Installation Hardware for Total Pen Systems

**CONTACT YOUR SSCI REPRESENTATIVE TO ORDER THE APPROPRIATE INSTALLATION
HARDWARE FOR YOUR FACILITY'S TOTAL PEN SYSTEM.**

Total Animal Pen Systems

HOW TO MEASURE FOR PEN SYSTEMS

It is important to accurately measure your space for your Total Animal Pen System to be sure the System will fit the way you envision it. Each Pen System is different depending on if you use stainless steel or masonry partitions and if you use facility walls for one or both end walls. Please take a moment to review this Measuring

information to help ensure you get the System you desire.

If you have questions, call your SSCI or local authorized representative for more information.

SFF
SRF

TOTAL ANIMAL PEN SYSTEMS WITH STAINLESS STEEL PARTITIONS

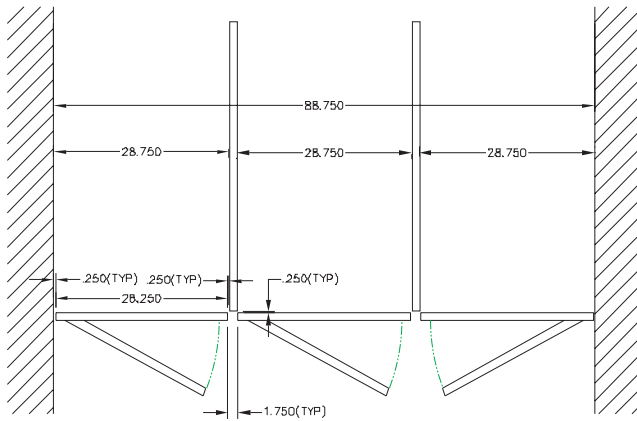

MEASUREMENTS

	IN.	CM.
Width of Stainless Steel Partition Panels:	1.250	3.18
Space between Partition Panels and Gates:	.250	.64
Space between End Walls and Gates:	.250	.64
Width of Gates:	28.250	71.75
	31.250	79.37
	34.250	87.00
	37.250	94.61
	40.250	102.23
	43.250	109.85
	46.250	117.48

For example: To build a Pen System using 28.250-in. (71.75cm) Gates and Stainless Steel Partition Panels and End Panels at both ends allow 28.250-in. (71.75cm) for each Gate, .25-in. (.64cm) on each side of the Gate and 1.25-in. (3.175cm) for each End or Partition Panel.

If you are using your facility's walls for end walls, simply subtract 1.25-in (3.175cm) for each End Panel you eliminate.

In this example, all pens in this System measure 28.750-in. wide (73.025cmW).

Please Note: Your Pen System may require more than one Gate width size in the run to best fit into the available area.

**MFF
MRF**

TOTAL ANIMAL PEN SYSTEMS WITH MASONRY PARTITIONS

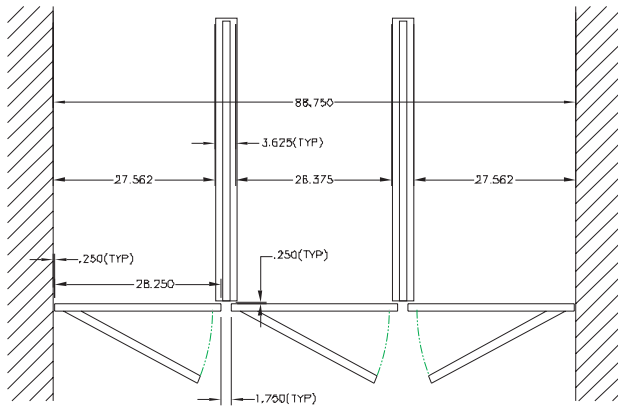

MEASUREMENTS	IN.	CM.
Width of Typical Masonry Partitions:	3.625	9.21
Amount Gates overlap face of Masonry Partitions:	.937	2.38
Space between Gates on face of Masonry Partitions:	1.750	4.45
Space between End Walls and Gates:	.250	.64
Width of Gates:	28.250	71.75
	31.250	79.37
	34.250	87.00
	37.250	94.61
	40.250	102.23
	43.250	109.85
	46.250	117.48

For example: To build a Pen System using 28.250-in. (71.75cm) Gates, 3.625-in (9.21cm) Masonry Partition Panels and Facility End Walls at both ends allow 28.250-in. (71.75cm) for each Gate; 1.25-in. (3.175cm) between each Gate; and .25-in (.64cm) on the side of the Gate that attaches to your facility's walls for end walls.

In this example, interior pens measure 26.375-in. wide (66.992cmW) and end pens measure 27.652-in. wide (70.236cmW). Raised-Floor Systems require Floor Brackets for End Walls at each end of the System in order to use the same size Coated Floor Sections in all interior pens and end pens.

Please Note: Your Pen System may require more than one Gate width size in the run to best fit into the available area.